



DAVIC 1.4 Specification Part 4
Delivery System Architecture And Interfaces
(Technical Report)

NOTICE

Use of the technologies described in this specification may infringe patents, copyrights or intellectual property rights of DAVIC Members or non-members.

Neither DAVIC nor any of its Members accept any responsibility whatsoever for damages or liability, direct or consequential, which may result from use of this specification.

© Digital Audio-Visual Council 1998.
Published by Digital Audio-Visual Council
Geneva, Switzerland

CONTENTS

<i>Foreword</i>	<i>v</i>
<i>Introduction</i>	<i>vi</i>
1. Scope	1
2. Informative references	1
3. Definitions	2
4. Acronyms and abbreviations	3
5. Conventions	3
6. The Delivery System	4
6.1. Definition and classification	4
6.2. Cabled Networks	5
6.3. Wireless Networks	6
7. Cabled networks	7
7.1. Core Network	7
7.1.1. Definition.....	7
7.1.2. Functions.....	7
7.2. Access Network	7
7.2.1. Definition.....	7
7.2.2. Classification of Access architectures.....	8
7.3. In-house network	12
7.3.1. Detailed in-house network architecture.....	13
7.3.2. Home Access Network (HAN) Architecture.....	13
7.3.3. Home Local Area Network (HLN) Architecture.....	14
7.3.4. Home Network Security Architecture.....	16
7.3.5. Single Security for Both the HAN and HLN.....	16
7.3.6. ATS Gateway Security Services.....	16
8. Wireless networks	17
8.1. Classification of wireless	17
8.2. MMDS	17
8.3. LMDS	18
8.4. Satellite network	18
9. Service Architecture	19
9.1. Enhanced and Interactive Broadcast service	19
9.1.1. Downstream architecture.....	20
9.1.2. Upstream architecture.....	20
9.1.3. Service Provider System architecture.....	20
9.2. Switched Video Broadcast service	21
9.2.1. Delivery of broadcast programs to the Replication Unit.....	23
9.2.2. Program Selection Protocol.....	24
9.3. Communicative services	25
10. Network and Service related control	26

10.1.	Definition	26
10.2.	Control functions	26
10.2.1.	Network functions	26
10.2.2.	Service functions	27
10.3.	Access to Core control flow.....	27
10.3.1.	Pure multiplexing of ATM UNI interfaces (VB5.1 configuration)	28
10.3.2.	Flexible allocation interface (VB5.2 configuration).....	28
10.3.3.	ATM addressing in the Access	28
10.3.4.	Routing in the ATM Access	29
11.	<i>Network and Service management</i>	29
11.1.	Management functions	29
11.1.1.	Service Management functions.....	29
11.1.2.	Network Management functions.....	29
11.2.	Management architecture.....	30
11.2.1.	Scenario 1	30
11.2.2.	Scenario 4	32
11.3.	Telecommunication Management Network Reference Model	32
11.4.	Network Management Protocols	33
11.5.	Reference Standards and Requirements	33

Foreword

The Digital Audio-Visual Council (DAVIC) is a non-profit Association registered in Geneva in 1994. The objective of DAVIC is to promote the success of interactive digital audio-visual applications and services through specification of open interfaces and protocols.

The DAVIC 1.4 Specification was developed by representatives of DAVIC member organizations. It is a public document based on submissions from members and non-members in response to the public Calls For Proposals which were issued in October 1994, March 1995, September 1995, December 1995, March 1996 and September 1996. The specification has full backward compatibility with the earlier versions [DAVIC 1.0](#), [DAVIC 1.1](#) and [DAVIC 1.2](#). [DAVIC 1.3](#) has been available on the Internet since June 1997. [DAVIC 1.3.1](#) is a point release issued in Milan, March 1998.

DAVIC 1.4 is a single specification consisting of 14 parts.

- [Part 1: Description of Digital Audio-Visual Functionalities](#)
- [Part 2: System Reference Models and Scenarios](#)
- [Part 3: Service Provider System Architecture](#)
- [Part 4: Delivery System Architecture and Interfaces](#)
- [Part 5: Service Consumer System Architecture](#)
- [Part 6: Management Architecture and Protocols](#)
- [Part 7: High And Mid-Layer Protocols](#)
- [Part 8: Lower-Layer Protocols and Physical Interfaces](#)
- [Part 9: Information Representation](#)
- [Part 10: Basic Security Tools](#)
- [Part 11: Usage Information Protocols](#)
- [Part 12: System Dynamics, Scenarios and Protocol Requirements](#)
- [Part 13: Conformance and Interoperability](#)
- [Part 14: Contours: Technology Domain](#)

The DAVIC PAS (Publicly Available Specification) forwarded to ISO/IEC JTC 1 for transposition into an international standard is a subset of the DAVIC 1.4 specification consisting of the normative parts (2, 6-12 and 14). In addition, the essential informative Part 1 which provides categorised sets of user and market requirements and has two informative annexes which are closely integrated with the normative technology conformance details provided in Part 14 is proposed as an ISO/IEC JTC 1 Technical Report.

All versions and corrigenda of DAVIC specifications are available from the DAVIC web site.

Contact Information

DAVIC Secretariat
c/o Societa' Italiana Avionica Spa
Strada Antica di Collegno, 253
I-10146 Torino - Italy
Tel.: +39 11 7720 114
Fax: +39 11 725 679
Email: secretariat@davic.org
DAVIC Home Page: <http://www.davic.org>

Introduction

DAVIC specifications define the minimum tools and dynamic behavior required by digital audio-visual systems for end-to-end interoperability across countries, applications and services. To achieve this interoperability, DAVIC specifications define the technologies and information flows to be used within and between the major components of generic digital audio-visual systems. Interoperability between these components and between individual sub-systems is assured through specification of tools and specification of dynamic systems behavior at defined reference points. A reference point can comprise one or more logical (non-physical) information-transfer interfaces, and one or more physical signal-transfer interfaces. A logical interface is defined by a set of information flows and associated protocol stacks. A physical interface is an external interface and is fully defined by its physical and electrical characteristics. Accessible reference points are used to determine and demonstrate compliance of a digital audio-visual subsystem with a DAVIC specification.

The Parts of the DAVIC 1.4 Specification can be classified into four major groups. A summary of each part under each of the four headings follows.

Requirements and Framework (Parts 1-2)

Part 1 provides a detailed listing of the functionalities required by users and providers of digital audio-visual applications and systems. It introduces the concept of a contour and defines the IDB (Interactive Digital Broadcast), EDB (Enhanced Digital Broadcast), and Institutional Multimedia Retrieval (IMR) functionality requirements which are used to define the normative contour technology toolsets provided in Part 14.

Part 2 defines the normative DAVIC technical framework. It provides a vocabulary and a Systems Reference Model, which identifies specific functional blocks and information flows, interfaces and reference points.

Architectural Guides (Parts 3-5)

Parts 3, 4 and 5 are technical reports which provide additional architectural and other information for the server, the delivery-system, and the service consumer systems respectively.

Part 3 defines how to load an application, once created, onto a server and gives information and guidance on the protocols transmitted from the set-top user to the server, and those used to control the set-up and execution of a selected application.

Part 4 provides an overview of delivery systems and describes instances of specific DAVIC networked service architectures. These include physical and wireless networks. Non-networked delivery (e.g. local storage physical media like discs, tapes and CD-ROMs) are not specified.

Part 5 provides a service consumer systems architecture and a description of the DAVIC Set Top reference points defined elsewhere in the normative parts of the specification.

Technology Toolsets (Parts 6-11)

The next six parts are normative. They specify and comprise the technology toolsets and relevant protocols across the entire audio-visual creation and delivery chain.

Part 6 specifies the information system model used for managing DAVIC systems. In particular, this part defines the managed object classes and their associated characteristics for managing the access network and service-related data in the delivery system. Where these definitions are taken from existing standards, full reference to the required standards is provided. Otherwise a full description is integrated in the text of this part. Usage-related information model is defined in Part 11.

Part 7 defines the technologies used for high and mid-layer protocols for DAVIC systems. In particular, this part defines the specific protocol stacks and requirements on protocols at specific interfaces for the DAVIC content, control and management information flows.

Part 8 defines the toolbox of technologies used for lower layer protocols and physical interfaces. The tools specified are those required to digitize signals and information in the Core Network and in the Access Network. Each tool is applicable at one or more of the reference points specified within the delivery system. In addition a detailed specification is provided of the physical interfaces between the Network Interface Unit and the Set Top Unit and of the physical interfaces used to connect Set Top Boxes to various peripheral devices (digital video recorder, PC, printer). The physical delivery system mechanisms included are copper pairs, coaxial cable, fiber, HFC, MMDS, LMDS, satellite and terrestrial broadcasting.

Part 9 defines what the user will eventually see and hear and with what quality. It specifies the way in which monomedia and multimedia information types are coded and exchanged. This includes the definition of a virtual machine and a set of APIs to support interoperable exchange of program code. Interoperability of applications is achieved, without specifying the internal design of a set top unit, by a normative Reference Decoder Model which defines specific memory and behavior constraints for content decoding. Separate profiles are defined for different sets of multimedia components.

Part 10 defines the interfaces and the security tools required for a DAVIC 1.4 system implementing security profiles. These tools include security protocols which operate across one or both of the defined conditional access interfaces CA0 and CA1. The interface CA0 is to all security and conditional access functions, including the high speed descrambling functions. The interface CA1 is to a tamper resistant device used for low speed cryptographic processing. This cryptographic processing function is implemented in a smart card.

Part 11 specifies the interface requirements and defines the formats for the collection of usage data used for billing, and other business-related operations such as customer profile maintenance. It also specifies the protocols for the transfer of Usage Information into and out of the DAVIC System. In summary, flows of audio, video and audio-visual works are monitored at defined usage data collection elements (e.g. servers, elements of the delivery system, set-top boxes). Information concerning these flows is then collected, processed and passed to external systems such as billing or a rights administration society via a standardised usage data transfer interface.

Systems Integration, Implementation and Conformance (Parts 12-14)

Part 12 is a normative part which defines system dynamic behavior and physical scenarios. It details the locations of the control functional entities along with the normative protocols needed to support the systems behavior. It is structured as a set of protocol walk-throughs, or “Application Notes”, that rehearse both the steady state and dynamic operation of the system at relevant reference points using specified protocols. Detailed dynamics are given for the following scenarios: video on demand, switched video broadcast, interactive broadcast, and internet access.

Part 13 is an informative report which provides guidelines on how to validate the systems, technology tools and protocols through conformance and / or interoperability testing.

Part 14 provides the normative definition of DAVIC Technology Contours. These are strict sets of Applications, Functionalities and Technologies which allow compliance and conformance criteria to be easily specified and assessed. DAVIC 1.4 contains the full details of three contours introduced in Part 1 of this Specification. Part 14 specifies required technologies and is a mandatory compliance document for contour implementations.

Place Holder for pdf blank page

1. Scope

Part 4 of this Specification gives an overview of Delivery Systems that are specified to carry DAVIC services. A representative set of **general** descriptions related to the wide DAVIC scope is given first, followed by an indication of the cases taken into consideration by DAVIC 1.4. Also instances of specific DAVIC 1.4 service architectures are described. The Delivery System includes a Core, an Access, Service and network related control and Network Management. Figure 1-1 is taken from Part 2 (Figure 7.8) and shows a reference model of a cabled Delivery System where a clear distinction is made between external (A1 and A9) and internal reference points and interfaces. The external reference points are necessary to be specified for end to end interoperability: Service Provider to Delivery system to Service Consumer Systems. The other reference points shown are not necessarily to be specified from an operator's point of view if one operator runs the whole Delivery System. The above limitation of interfaces specification, however, is not enough for world wide interoperability because of the necessity of many operators involved in delivery systems, between which specified interfaces must be implemented.

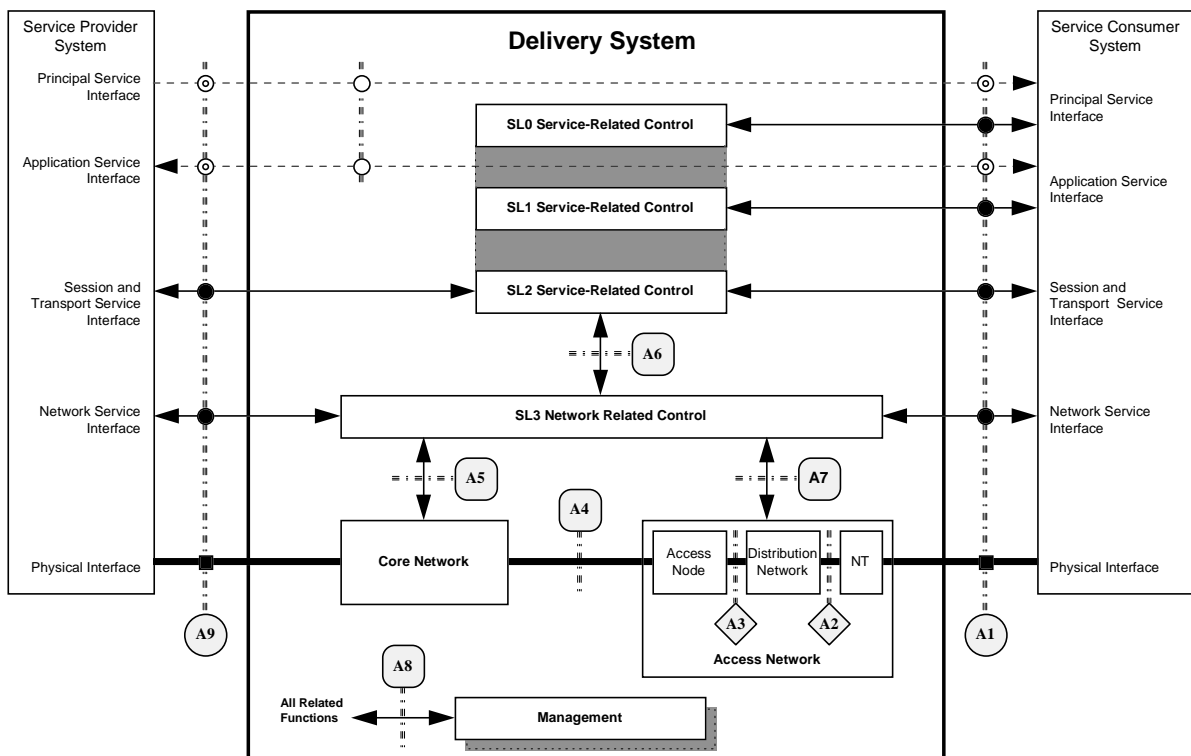

Figure 1-1 Delivery System Control Plane model

2. Informative references

There are no normative references in this Technical Report. At the time of publication, the editions indicated were valid. All referenced documents are subject to revision, and parties to agreements based on this Specification are encouraged to investigate the possibility of applying the most recent editions of the standards indicated below. Members of IEC and ISO maintain registers of currently valid International Standards. The Telecommunication Standardization Bureau (TSB) maintains a list of currently valid ITU-T Recommendations. The following references are provided for information.

ANSI Standard T1.413 Network and Customer Installation Interface-Asymmetric Digital Subscriber Line (ADSL)-Metallic Interface, March 1995

DE/SPS-03047: V interfaces at the digital Service Node (SN), interfaces at the VB5.2 reference point for the support of broadband or combined narrowband and broadband Access Networks

prEN 301-005-1 (DE/SPS-03046-1): V interfaces at the digital Service Node (SN), Interfaces at the VB5.1 reference point for the support of broadband or combined narrowband and broadband Access Networks (ANs): Part 1: Interface Specification

ETR 257: Signaling Protocols and Switching V interfaces at the digital Service Node (SN), Identification of the applicability of existing protocol specifications for a VB5 interface in an access arrangement with Access Networks (DTR/SPS-03040)

3. Definitions

This Section defines new terms, and the intended meaning of certain common terms used in this Specification. Part 2 Annex A defines additional terms and, in some cases, alternative interpretations that are appropriate in other contexts. The definitions in the annex were derived from various sources: some are direct quotes, others have been modified.

Supplementary definitions in Part 2 Annex A are not normative and are provided for reference purposes only. For the purposes of this Specification, the following definitions apply.

Access Network: a part of the Delivery system consisting of a collection of equipment and infrastructures, that link a number of Service Consumer Systems to the rest of the Delivery system through a single (or a limited number of) common port(s).

Access Node: The element of the Access Network containing centralized functions responsible for processing information flows in preparation for transport through the selected distribution network.

Core Network: a portion of the Delivery system composed of networks, systems, equipment and infrastructures, connecting the Service Providers to the Access Networks.

NOTE: The term Core Network, in the DAVIC use, is wide sense as it includes the notion of the access networks that are needed to link the Service Providers Systems to the core network in strict sense (i.e., exclusive of any access network). This kind of access networks is not under consideration within DAVIC.

Delivery System (DS): The portion of the DAVIC System that enables the transfer of information between DS-users.

Distribution Network: a collection of equipment and infrastructures that delivers information flows from the Access Node to the Network Termination elements of the Access Network.

Interface: a point of demarcation between two blocks through which information flows from one block to the other. See logical and physical interface definitions for further details. A DAVIC interface may be physical-interface or a logical-interface.

Logical interface: an interface where the semantic, syntactic, and symbolic attributes of information flows are defined. Logical interfaces do not define the physical properties of signals used to represent the information. A logical interface can be an internal or external interface. It is defined by a set of information flows and associated protocol stacks.

Network Interface Unit (NIU): The NIU accepts network specific content-information flows from the Delivery system and provides a non-network specific interface to the Connectivity Entity in the STU. (additional definitions of the NIU may exist)

Network Related Control: The Network Related Control entity provides control functions for network configuration, connection establishment and termination and information routing in a network instance of a Delivery system.

Network Termination (NT): the element of the Access Network performing the connection between the infrastructure owned by the Access Network operator and the Service Consumer System (ownership decoupling). The NT can be passive or active, transparent or not.

Physical interface: An interface where the physical characteristics of signals used to represent information and the physical characteristics of channels used to carry the signals are defined. A physical interface is an external interface. It is fully defined by its physical and electrical characteristics. Logical information flows map to signal flows that pass through physical interfaces.

Reference point: a set of interfaces between any two related blocks through which information flows from one block to the other. A reference point comprises one or more logical (non-physical) information-transfer interfaces, and one or more physical signal-transfer interfaces.

Service Related Control: an entity that provides all control functions for the services that are offered by a network instance of the Delivery system. The DSRM allows for SL0, SL1 and SL2 Service Related Control subsets.

Telecommunications Management Network (TMN): a network consisting of Operations Support Systems (OS) and data networking facilities whose purpose it is to provide management capabilities for telecommunications networks, network elements, resources and services.

4. Acronyms and abbreviations

Part 2 Annex B contains a complete set of acronyms and abbreviations used throughout the DAVIC 1.4 Specification. The following acronyms and abbreviations are used in this Specification:

ADSL	Asymmetric Digital Subscriber Line
AN	Access Network
ATM	Asynchronous Transfer Mode
BCC	Bearer Channel Connection
BCU	Broadcast Control Unit
CATV	Community Antenna TV
CMIP	Common Management Information Protocol
CPS	Content Provider System
FTTB	Fiber to the Building
FTTC	Fiber to the Curb
FTTH	Fiber to the Home
HFC	Hybrid Fiber Coax
ISDN	Integrated Services Digital Network
IWU	Interworking Unit
LAN	Local Area Network
LE	Local Exchange
LMDS	Local Multipoint Distribution System
MAC	Medium Access Control
MIB	Management Information Base
MMDS	Multi-channel Multipoint Distribution System
MOD	Movies on Demand
MPEG	Moving Pictures Expert Group
MPEG-TS	MPEG-Transport Stream
NIU	Network Interface Unit
NMS	Network Management System
NOD	Network Ownership Decoupling
NRC	Network Related Control
NT	Network Termination
OAM	Operation, Administration and Maintenance
ONU	Optical Network Unit
PLMN	Public Land Mobile Network
PON	Passive Optical Network
PSTN	Public Switched Telephony Network
QoS	Quality of Service
RU	Replicator Unit
SCS	Server Provider System
SNMP	Simple Network Management Protocol
SPS	Service Provider System
SRC	Service Related Control
STB	Set Top Box
STU	Set Top Unit
TMN	Telecommunication Management Network
TTD	Transmission Technology Decoupling
UNI	User Network Interface
UPI	User Premises Interface
VC	Virtual Channel
VCI	Virtual Channel Identifier
VDSL	Very high bit rate Digital Subscriber Line
VP	Virtual Path
VPI	Virtual Path Identifier

5. Conventions

The style of this Specification follows the Guide for ITU-T and ISO/IEC JTC 1 co-operation. Appendix H: Rules for presentation of ITU-T | ISO/IEC common text (March, 1993).

6. The Delivery System

Within DAVIC the term 'Delivery System' has a very broad meaning. It refers to virtually any means to deliver information from one entity to another entity in order to support services defined by DAVIC. Entities involved are, among others, Content Provider Systems (CPS), Service Provider Systems (SPS) and, of course, Service Consumer Systems (SCS). Figure 6-1 depicts the **general** DAVIC model showing how the various entities are connected to the Delivery System and through which reference points. Service Providers can download content from the Content Providers and offer this content to End-Consumers.

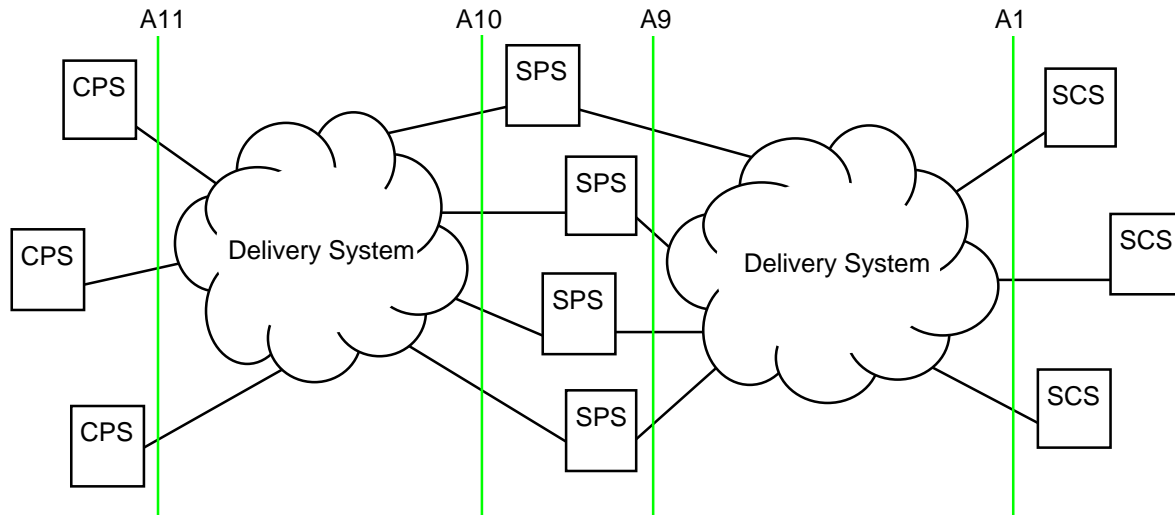

Figure 6-1 **General** DAVIC model with communication entities, Delivery System and reference points.

For DAVIC 1.4 the Delivery System between reference A1 and A9 is considered. This Delivery System is essential to bring the services offered by the Service Provider to the End-Consumers. In future versions of the DAVIC specifications, the Delivery System between the reference points A10 and A11 will be specified as well to ensure easy transfer of content between the Content Providers and the Service Providers.

The Delivery System may consist of several Delivery System domains owned by different network operators. At the boundaries of these domains a new reference may have to be defined in order to guarantee interoperability between Delivery System domains and to ensure end-to-end interoperability.

6.1. Definition and classification

The main purpose of a Delivery system is to transfer information between Delivery system users. Delivery system refers to virtually any means and medium to transfer information. Types of Delivery Systems range from tapes and discs, via telecommunication networks to satellite broadcast systems.

Depending on the type of Delivery system used, network and management functions are required to enable the Service Provider to offer a reliable and high quality service to the End Consumers.

Figure 6-2 shows a classification of Delivery system considered by DAVIC.

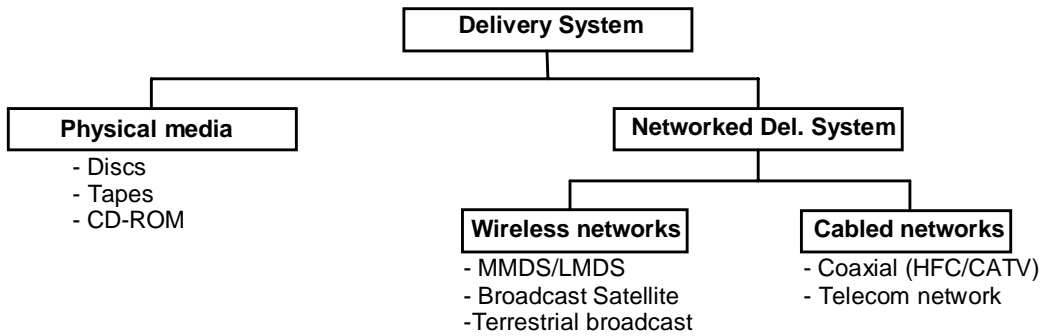

Figure 6-2 Classification of Delivery Systems.

The main distinction in Delivery systems is between networked Delivery systems and non-networked Delivery systems. The latter consists of local storage physical media like discs tapes and CD-ROMS. This type of is not specified in DAVIC 1.4 and is left for future versions of the DAVIC specifications. Networked Delivery system can be split into wireless and cabled.

Wireless networks do not use wired physical media to transport signals to the End Users. Wireless networks include among others one-way systems such as uni-directional MMDS, two-way systems like bi-directional MMDS and LMDS, direct broadcast satellite and terrestrial broadcasting systems. Cabled networks use physical cables and media to transport signals to the End Users. Examples of cabled are telecommunication networks and cable operator networks.

The [general](#) architectures for cabled and wireless will be described below. More detailed descriptions follow in the subsequent clauses.

6.2. Cabled Networks

The [general](#) architecture of a cabled network is shown in Figure 6-3. A cabled network Delivery System is split into a Core, an Access and an in-house network. The separation between the Core and the Access is formed between the Local Exchange (LE) and the Access (AN). The separation between the Access and the in-house network is formed by the Network Termination (NT). DAVIC considers the Access and the Network Termination to be part of the Access.

Besides the reference A1 and A9 (corresponding to Figure 6–1), other reference points are shown as well: A0, A1*, A2, A3 and A4. These reference points separate the various system entities.

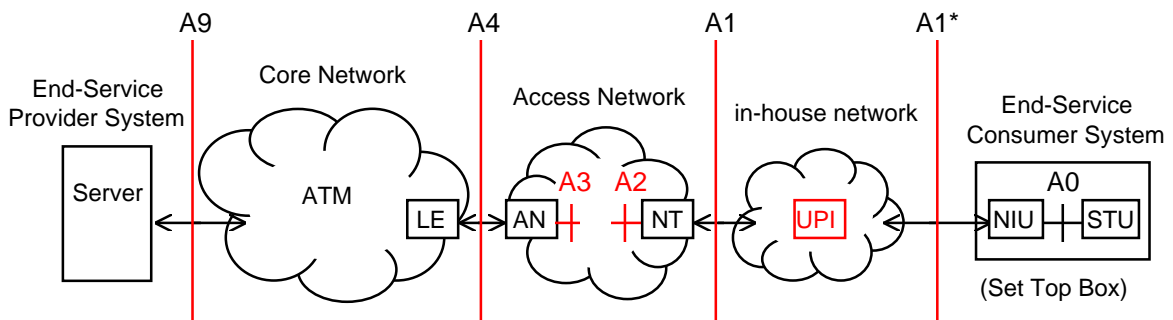

Figure 6-3 Architecture of a cabled network including reference points.

Generally the End-Service contains a Set Top Box (STB) that can be divided into two parts, a network independent part called the Set Top Unit (STU) and a network dependent part called the Network (NIU). In between, a reference A0 is defined that forms the separation between the network independent part and the network dependent part.

The in-house network exists between the NT and the Set Top Box. Reference A1 is defined at the in-house network side of the NT. For DAVIC 1.4 the STB is connected directly to the NT, therefore the interfaces and protocols at the NIU has to comply with A1. However, it is foreseen that future versions of DAVIC specifications may contain specific in-house networks such as in house LANs, Home Bus, or switched in-house networks. The

User Premises Interface (UPI) has been defined as a placeholder for these types of in-house networks. As a consequence of introducing a UPI a reference A1* is introduced. For DAVIC 1.4 A1 and A1* are identical. However, in future versions of the DAVIC specifications A1* may be a superset of A1 incorporating new in-house network architectures.

The reference A1 is defined between the Access and the End Consumer in-house network. In case of a passive NT, the reference A2 and A1 are identical. Due to possible and optional active components inside the Access, A2 and A3 may differ. At the other side of the Access reference A4 is defined between the Access and the Local Exchange (LE). The Access takes the signals from the Core and makes adaptations for transport in the Access.

The Local Exchange is the first switching unit seen from the customer premises site. The local exchange belongs to the Core. The Core contains network functions to establish, maintain and tear down connections and sessions. Moreover, the Core provides network management functions.

6.3. Wireless Networks

Wireless networks like MMDS, LMDS, direct broadcast satellite and terrestrial broadcast networks are, in the downstream direction, distributive in nature. To provide interactive services in wireless networks either a return path has to be defined for this network or a separate network is required to act as a return path. The architecture shown in Figure 6-3 is applicable for the return channel. This architecture is valid for bi-directional MMDS and LMDS. Figure 6-4 shows the architecture for wireless networks requiring a separate return path network for interactivity. Examples are uni-directional MMDS and satellite.

Figure 6-4 shows a satellite as an example of a wireless Delivery system requiring a separate network as return path. In the downstream direction (from Service Provider to End Consumer) the Service Provider, or rather the distribution source, transmits its broadcast signals via a core to an uplink transmitter in case of a satellite. The Core between the broadcast server and the uplink transmitter can range from a single wire to a fully-fledged switched Core. In the latter case an ATM Core is recommended to comply with the cabled Core. The uplink transmitter sends the signals to the satellite. The satellite broadcasts the signals in a wide geographical area where satellite dishes owned by the End-Service Consumers pick up the signals. The signals are offered to the Set Top Box to be displayed on a TV or computer.

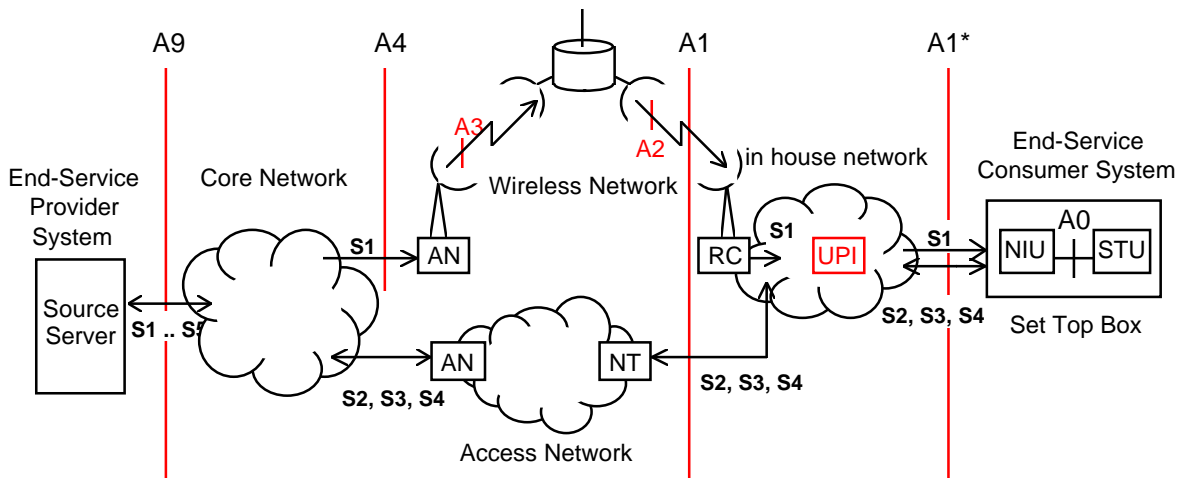

Figure 6-4 Architecture of a wireless network including reference points.

To allow interactivity (e.g. for enhanced services) a return path network is required. The flows to be carried across the return path network depend on the actual service. In any case the application control flow (S2) and connection control flow (S4) have to be carried, while session control (S3) and management information (S5) may be carried depending on the application.

As in the cabled network model, the return path signals pass an Access and a Core before they arrive at the Service Provider System. The return path network could be the same, a different one or partly different from the Core used for downstream transmission.

7. Cabled networks

7.1. Core Network

7.1.1. Definition

The Core network provides switched connections from and to Content Provider Systems, Service Provider Systems (servers and brokers) and, via an Access network, to End Consumer Systems. The Core can be as small as one switch or may extend to a worldwide network.

7.1.2. Functions

It is not the intention of DAVIC to define any particular architecture for the Core. However, DAVIC expects the following functions to be provided by the Core network:

- Reliable transfer of information between entities like Content Provider Systems, Service Provider Systems and Access. The Access takes care of the distribution to the End Consumers.
- Switching functionality to provide connections between entities.
- Network functions for addressing and to establish and release connections. The Network functions are described in clause 10 of this document.
- Network Management functions for network configurations, performance and fault monitoring, billing and accounting purposes. Network Management is described in clause 11 of this document.

Within DAVIC it is assumed that the multiplexing and switching technique in the Core is ATM. ATM allows to establish connections of virtually any bit rate up to the maximum capacity of the transmission links. ATM does not impose any restrictions on the topology of the Core.

According to the reference model shown in Figure 1–1, taken from Part 2, the server is connected directly to the Core. This implies that the server has only ATM interfaces.

7.2. Access Network

7.2.1. Definition

The Access network is defined as a collection of equipment and infrastructures performing the following functions:

- Transmission, multiplexing, concentration and broadcasting of service/application information flows between the end users of a given area and the rest of the Delivery System (Core and servers),
- Relevant control and management functions,
- Transport of other services (telephony, analogue TV, N-ISDN services, etc.).

The Access network consists of the Access Node (AN), the Network Termination (NT) and the Distribution network in between them, see Figure 7-1. The Access network may have multiplexing and cross-connecting functionality but has no switching functionality.

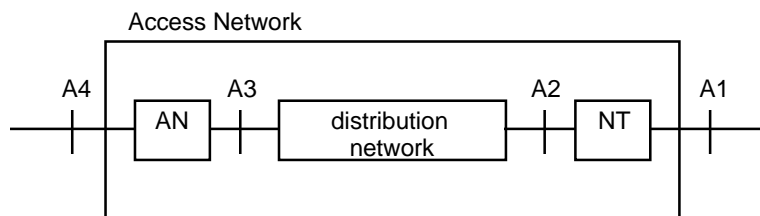

Figure 7-1 The generic model of the Access Network.

With respect to the Access DAVIC 1.4 is only concerned with the interfaces and protocols at the A4 and A1 reference, i.e., at the edges of the Access. Reference A2 and A3 are considered less critical and are left to future versions of the DAVIC specifications.

7.2.1.1. The Access network

The Access network performs the adaptation between the Core and the Access. It processes the information flows such that they can be transported through the selected distribution network.

7.2.1.2. The distribution network

The distribution network takes care of the actual transport of signals from the Core to the customer's premises. The distribution may take various topologies, e.g., point-to-point star topology or a shared bus architecture. Also the transmission medium and transmission protocols may change inside the distribution. In this case interfaces and signals may differ at reference A2 and A3.

7.2.1.3. The Network Termination

The primary function of the Network Termination is to form a legal separation between the Access Network owned by the network operator and the in-house network owned by the End Consumer. This function is called the Network Ownership Decoupling (NOD). The NOD function can be as simple as a wall socket, as long as there is a visible point where the ownership changes. There is always an NT having at least the NOD function.

Besides Network Ownership Decoupling, the NT may have another function. It may terminate the medium and transmission technology used in the Access and adapt the signals to a different medium with a different transmission technology in the customer premises. This function is called the Transmission Technology Decoupling (TTD) function. For example in case of a fiber Access, the fiber may be terminated in the NT and the signals may be taken from the fiber and put on coaxial cable or twisted pair wires in the home.

If required, in addition the NT may bear operation and maintenance functions, e.g., measurement functions to facilitate the network operator to check and monitor the quality of the Access.

Depending upon the type of functions inside the NT, two types of NTs can be discerned:

- Passive NT
- Active NT

The passive NT bears the NOD function and maybe some passive adaptation to the in-house network, e.g., passive filters. The active NT bears the NOD function and may have active components to adapt, convert and change the medium and transmission technology from the Access to the in-house network.

The distinction between a passive NT and an active NT is essential since DAVIC 1.4 specifies the interfaces and protocols at the A1 reference. In the case of a passive NT, the medium and protocols at A2 and A1 are equal. This means that the actual medium and protocols used in the distribution have to be specified. In the case of an active NT, the medium and protocols at reference A2 and A1 may differ. Since only A1 needs to be specified, the actual topology, medium and transmission protocols used in the distribution are not relevant for an Access Network with an active NT.

7.2.2. Classification of Access architectures

Access can be classified in many ways. Access can be classified for example according to the medium that is used or the topology of the Access. Another distinction can be made based on whether the NT is a passive or an active element.

The classification used in this Part is shown in Figure 7-2. The first distinction is made whether the NT is active or passive. In case of an active NT, the Access is terminated before the A1 reference point. In that case the actual type of Access is not relevant, it could be e.g. FTTH, FTTC, HFC, as long as at reference A1 a DAVIC compliant protocol stack is present.

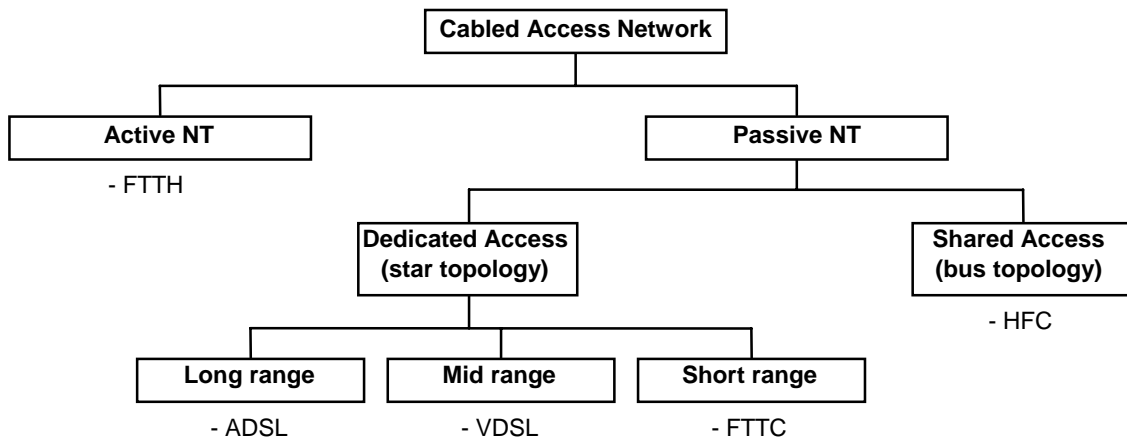

Figure 7-2 Classification of cabled Access Networks.

In the case of a passive NT, a further distinction can be made whether the End Consumers share the medium in the Access or not. A 'shared access' Access has typically a bus topology. An HFC network is an example of an Access where several End Consumers share the medium.

The alternative is that each End Consumer has its own 'dedicated access' to the Access. A 'dedicated access' Access has typically a star topology towards each End Consumer. However, it is not precluded that within the End Consumer premises a shared bus topology exists.

The 'dedicated access' Access can be further subdivided into a long range, a mid range and a short range with respect to the last copper drop (twisted pair or coax). An example of a long range 'dedicated access' Access is an ADSL Access. An example of a mid range 'dedicated access' Access is a VDSL Access. An example of a short range 'dedicated access' Access is a FTTC Access.

The various types of Access are described in more detail in the subclauses below.

7.2.2.1. ADSL copper Access

In a copper Access special techniques are required to upgrade the copper plant to support the high bit rates required for services specified by DAVIC. One method to upgrade the copper Access Network is to use Asymmetric Digital Subscriber Line (ADSL). ADSL is typically used to cross long range distances between 1500 meters and 5000 meters.

ADSL modems provide an asymmetrical digital bit pipe, with a high bit rate channel towards the customer and a low bit rate channel from the customer towards the network. ADSL allows bit rates ranging from 2 Mbit/s for 5 km loops up to 7 Mbit/s for shorter loops from the network to the customer. In the upstream direction (from customer to the network) the typical capacity ranges up to 640 kbit/s.

ADSL offers a point-to-point architecture between a central office ADSL modem located in the Access Node, and the subscriber ADSL modem located at the End Consumers premises. Figure 7-3 shows an ADSL Access with a passive NT.

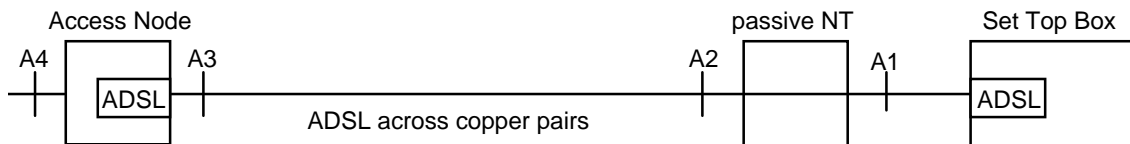

Figure 7-3 Example of an ADSL Access Network with a passive NT.

In the case of a passive NT the medium and the protocols at reference A1, A2 and A3 are equal. In this scenario ADSL has to be specified since these signals are crossing the A1 reference. Refer to Part 8 for the DAVIC 1.4 physical.

ADSL is specified in ANSI standard T1.413; see Part 8, clause 7.3 for more details. Work is ongoing in ETSI and the ADSL Forum.

7.2.2.2. VDSL copper Access

For medium range copper loops (in the range of 300 meters to 1500 meters) Very high bit rate Digital Subscriber Loop (VDSL) modems can be used. Due to the shorter range compared with ADSL, VDSL allows higher bit rates in up- and downstream direction. Bit rates from 10 Mbit/s to 52 Mbit/s are being considered as are both asymmetrical and symmetrical systems considered.

Figure 7-4 shows an example of a VDSL Access. The topology of a VDSL architecture is expected to be point-to-point. Since VDSL spans only a medium range, the location of the VDSL modems will typically be in a box between the Access and the Network, e.g. in a Optical Network Unit (ONU).

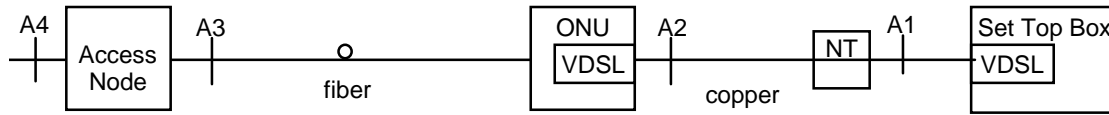

Figure 7-4 Example of a VDSL Access Network with a passive NT.

ANSI and ETSI have started work on VDSL, refer to contributions and documents in these bodies for the status of this work.

7.2.2.3. FTTC Access

The FTTC architecture consists of fiber in the Access up to a curb unit called the Optical Network Unit (ONU), typically located somewhere in a street/curb (FTTC) or in a large building (FTTB) serving some tens of subscribers. The last drop, typically in the order of 300 meters, to the subscribers makes use of coaxial cable or twisted pairs. Each customer is connected with its own twisted pairs or coaxial cable to the ONU, i.e., customers do not share the capacity on the medium in the last drop. Special modulation techniques are required in the twisted pair or coaxial part to allow a high bit rate towards the subscriber.

Figure 7-5 shows an example of a FTTC network with fiber between the Access and the ONUs inside in the Access. The ONU is located at the curb where optical to electrical conversion takes place and where the signals are made suitable for the twisted pair or coax in the last drop. Figure 7-5 shows a FTTC Access with passive NTs. For an active NT Access scenario, refer to clause 7.2.2.5.

Because the NT is passive, the medium and the signals at reference A1 and A2 are identical. However, reference A3 differs since it contains optical signals rather than electrical signals.

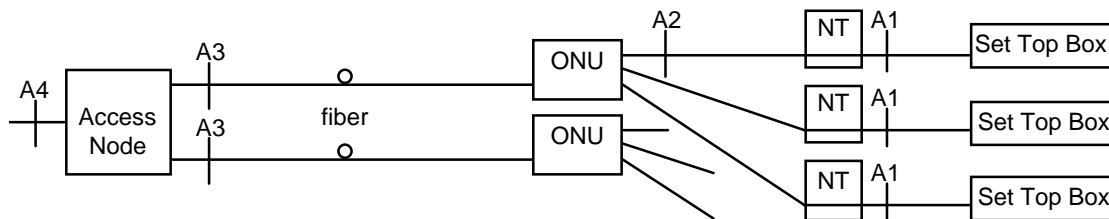

Figure 7-5 Example of a FTTC Access Network with a passive NT.

7.2.2.4. HFC Access

General

The HFC Access is based on a fiber part and a coaxial part. The fiber extends from the Access to a 'neighborhood node'. This neighborhood node serves typically about 100 to 500 subscribers via coaxial cable. These subscribers share the same cable and thus the available capacity of this cable. Because several subscribers share the same downstream and upstream bandwidth, special requirements like privacy and security measures have to be taken. Moreover a special medium access control (MAC) scheme is required in the upstream direction to prevent collision of information from customers to the network.

Figure 7-6 shows an example of an HFC Access. Fiber extends from the Access to a 'neighborhood node'. The 'neighborhood node' performs optical to electrical conversion and makes the signals suited to be transported across

the coaxial network. The coaxial cable serves several subscribers (bus topology) and is fed through a passive NT to the Set Top box. Refer to clause 7.2.2.5 for a scenario with an active NT.

Because this scenario is based on a passive NT, the medium and protocols at reference A1 and A2 are identical. However, the medium and lower layer protocols are different at reference A3.

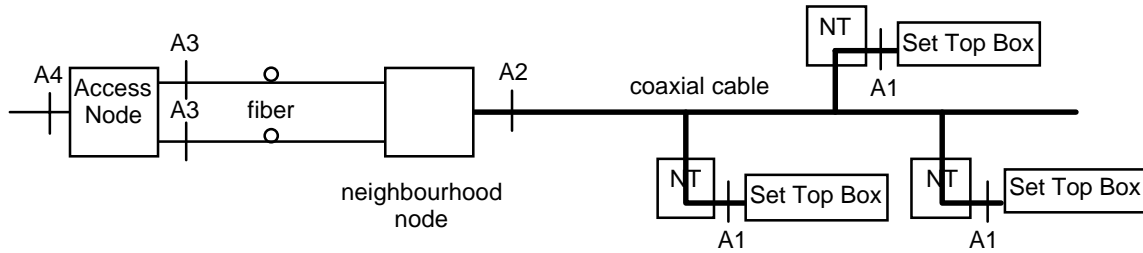

Figure 7-6 Example of an HFC Access Network with a passive NT.

7.2.2.5. Access with active NTs

Since only A1 will be specified (not A2 and A3), in the case of an active NT, DAVIC 1.4 actually does not care about the Access. The active NT may perform signal processing and adaptation to other media and protocol conversion. The Access may have any implementation as long as at the in-house network side of the NT, at reference A1, the specified protocol stacks in Part 12 are applied.

Figure 7-7 shows an example of an Access with an active NT. In this example the Access Network is a copper plant with ADSL or VDSL technology. The actual transmission technology used is not relevant for DAVIC 1.4. The active NT terminates the ADSL/VDSL signals and adapts the signals to the transmission technology used in the in-house network.

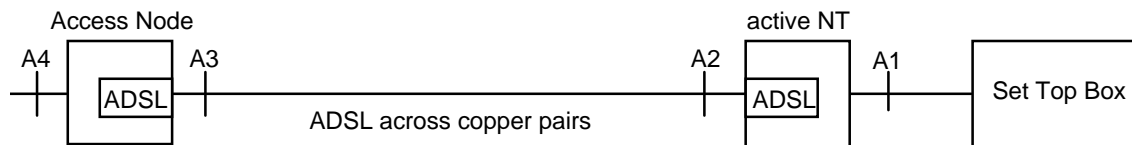

Figure 7-7 Example of an ADSL/VDSL Access Network with an active NT.

Another example of an active NT architecture is shown in Figure 7-8. This example shows a FTTH case with a passive optical network (PON) in the Access. The active NT terminates the PON and adapts the signals to a possible new medium with a different transmission technology. Another FTTH architecture may be a star architecture with direct fiber between the Access and the NT.

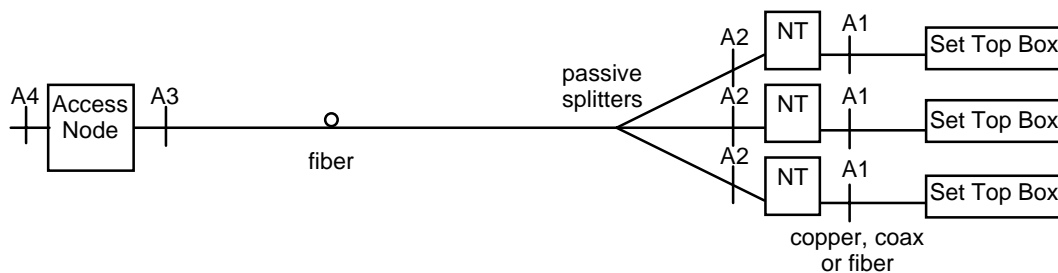

Figure 7-8 Example of a FTTH Access Network (PON) with an active NT.

Note—An active NT allows several interfaces to be offered to the End Consumers. The use of an ISDN interface for the reverse channel for S2, S3 and S4 information flows is being considered to support unidirectional passband coaxial interfaces.

7.3. In-house network

The in-house network exists between the NT and the End-Consumer Equipment, such as a Set Top Box. The in-house network may range from a simple wire to a complete in-house network with local switching functionality. The in-house network may have a bus topology on which equipment can be hooked to, or a may have a star architecture with point-to-point lines to a central (switching) unit. It can also consist of a combination of both. The actual systemspecification for an in-house network is left for future versions of DAVIC specifications. However, DAVIC 1.4 contains an architectural overview of the in-home network. These architectures are described in paragraph 7.3.1. Figure 7-9 shows the reference configuration for a very simple in-house network. In this reference configuration the Set Top Box (STB) is expected to be plugged directly into the NT.

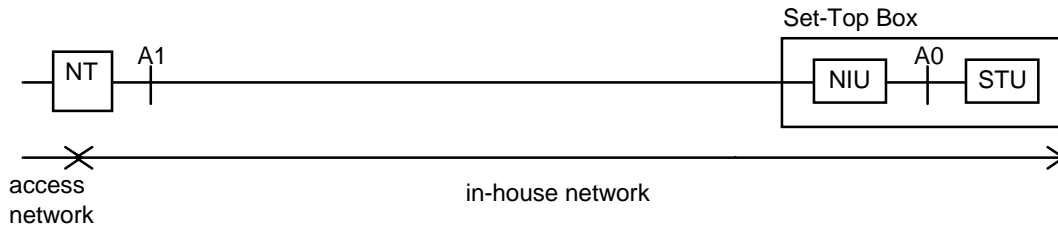

Figure 7-9 In-house network reference configuration.

Several Set Top Boxes can be used together in a bus topology as shown in Figure 7-10. The number of Set Top Boxes that can be connected like this depends on the actual Physical Layer used. Moreover, the Physical Layer must support a Medium Access Control (MAC) protocol to control access to the medium in the upstream (i.e., from Set Top Box to NT) direction.

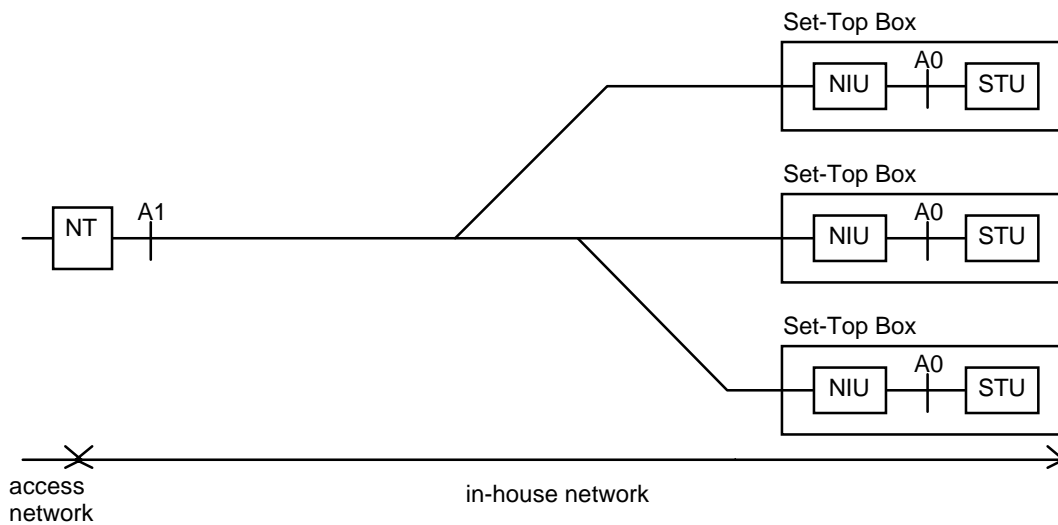

Figure 7-10 Connecting multiple STBs via a passive bus topology.

More advanced in-house networks are described in paragraph 7.3.1. A general figure of such advanced in-house network is shown in Figure 7-11. The User Premises Interface (UPI) comprises the technology for this in-house network. As a consequence of the introduction of the UPI a new reference A1* emerges. This reference is located between the UPI and the NIU inside the Set Top Box. Interfaces and protocols at A1* have to be a subset of the interfaces and protocols at A1, since it must be possible to connect the Set Top Box directly to the NT.

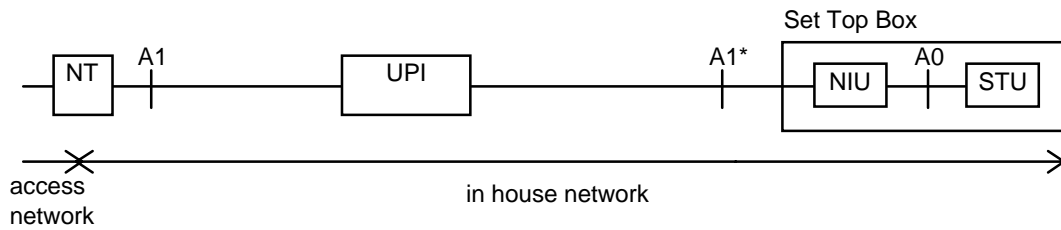

Figure 7-11 Example of a more advanced in-house network.

The following paragraphs will give a more detailed description of current in-home network architectures contained in DAVIC 1.4.

7.3.1. Detailed in-house network architecture

Figure 7-12 provides a general overview of Home Network SCS Architectures. The DAVIC SCS Home Network systems are functionally divided into Home Access Networks, and Home Local Area Networks. Detailed functional requirements for HAN and HLN components are provided in Parts 1 and 2 of this Specification.

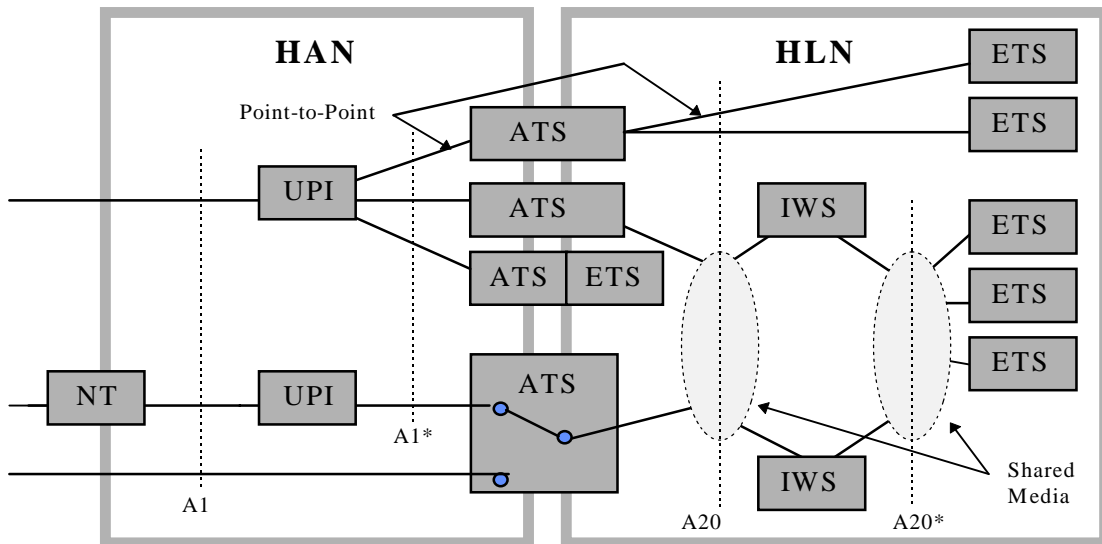

Figure 7-12: SCS Home Network Architecture Overview

Sections 0 and 0 provide for the HAN and HLN separately. Section 0 offers [general](#) architectures for security tools in the SCS Home Network systems.

7.3.2. Home Access Network (HAN) Architecture

In Part 2 of the DAVIC specifications, the functional requirements of the HAN are detailed. In essence, the HAN is an extension of the DAVIC Delivery System access network to multiple devices within the home. The User Premises Interface provides separation between the HAN media at the A1* reference point. The UPI may be totally passive, or exchange limited S5 flows with other A1* devices, called Access Termination Systems. These key HAN elements are shown in Figure 7.13 ..

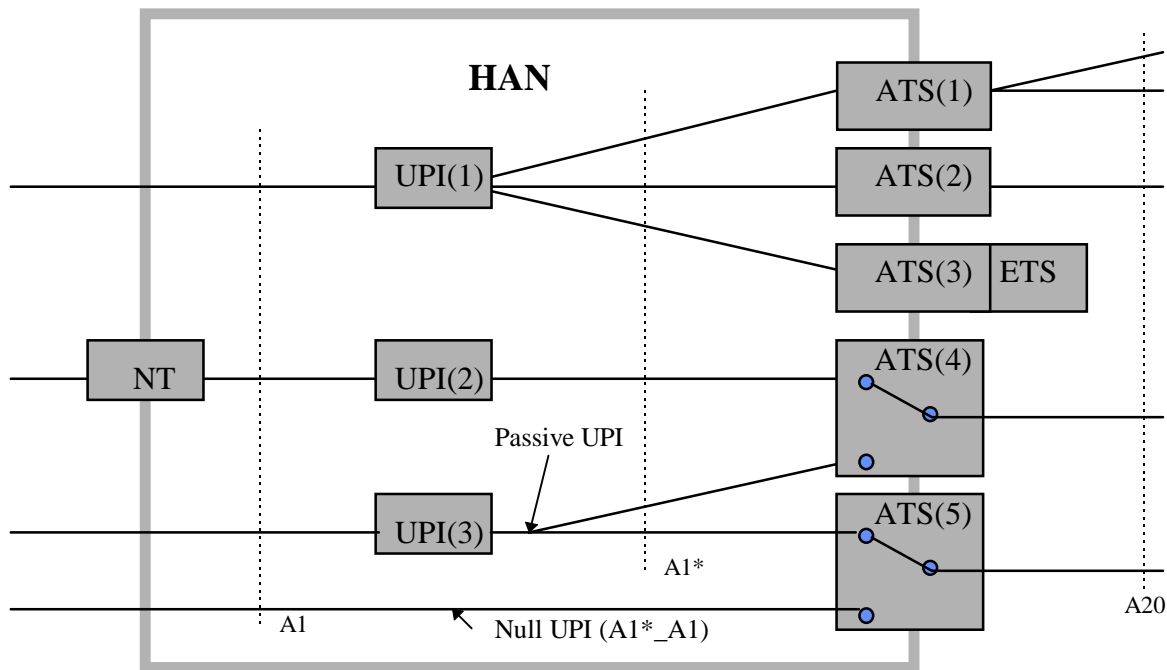

Figure 7-13: Home Access Network Architecture Elements

Requirements for HAN systems include:

1. A single HAN may service multiple ATS devices as shown between UPI(1) and ATS(1), ATS(2), and ATS(3).
2. An ATS device may physically connect to multiple HANs, but DAVIC only provides tools for one HAN to be active at any given time. This is represented by the switch in ATS(4) and ATS(5).
3. It is possible to have a passive or active UPI. A passive UPI may simply consist of wire with splitters as with most analog coax cable TV networks today. UPI(3) connecting into ATS(4) and ATS(5) is an example of such a HAN.
4. An active UPI as shown in UPI(1), may use S5 flows to manage connections among multiple ATS devices.
5. If the UPI function is null (no splitters or S5 flows in the HAN), then the A1* interface collapses to the A1 interface technology. This is shown on the lower connection of ATS(5).
6. While not shown in the figure, the HAN media may function as a shared media system in addition to the point to point systems illustrated.
7. ATS devices may connect to one or more ETS devices as shown by ATS(1) and ATS(2) via a Home Local Area Network (HLN) system at the A20 interface. Information regarding HLN architectures can be found in Section 0.
8. In the case of ATS(3), the device includes some ETS functionality; therefore, has no need for an A20 interface.

These HAN architectures allow DAVIC 1.0 to 1.4 ATS devices (e.g. DAVIC Set Top Box or Set Top Boxes plus PCs) and ATS devices designed to take advantage of the HLN to be intermixed by the Service Consumer System.

7.3.3. Home Local Area Network (HLN) Architecture

The HLN functions much like a traditional LAN environment, with the ATS devices acting as gateways to the DAVIC service provider applications. The HLN may also support separate applications with no dependencies to service provider resources or content. As with the HAN, the HLN may support multiple service providers through multiple ATSs.

In addition, IWS devices provide additional translation of physical media and S3, S4, and S5 protocols inside the HLN to extend its reach beyond single room and limited bandwidth applications.

Figure 7-14 shows the key components of an HLN system.

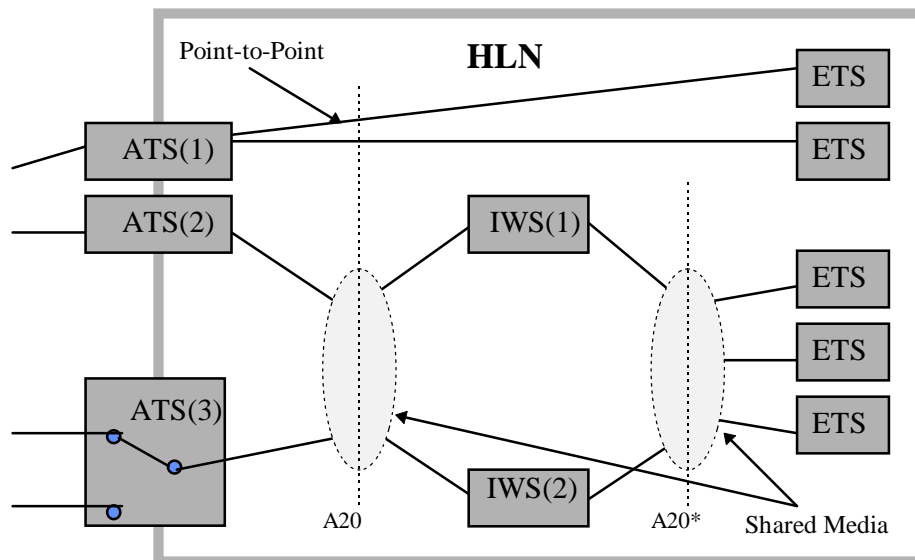

Figure 7-14: Home Local Area Architecture Elements

Requirements for HLN systems include:

1. The ATS may directly connect to the ETS as shown by ATS(1). Direct connections require the A20 interface technologies at the ATS and ETS to be identical for physical media and all S-flows.
2. The ATS may indirectly connect to ETSs through an IWS as shown from ATS(2) and ATS(3). The IWS device may be active or passive. The IWS devices IWS(1) and IWS(2) illustrated in Figure 7-14 are active and provide bridging between a shared media A20 HLN network to a cluster of ETS devices on a A20* shared media system.
3. Passive IWS devices (not shown in Figure 7-14) transparently pass all S-flows between devices connected to the HLN at the A20 interface (ATSs, IWSs, or ETSs) and device connected to the HLN at the A20* interface (IWSs and ETSs only). Copper or optical repeaters are excellent examples of passive IWS devices.
4. It is important to note that S1 and S2 flows pass transparently throughout the HLN. IWS devices do not interact with other HLN devices above the S3 flow level. This distinction is further underscored by the fact that ETS and ATS devices may provide gateways to non-DAVIC content or services, but IWSs (due to their non-interaction at the S1 and S2 flow level) may not act as such gateway devices.
5. The A20 and A20* HLN systems may utilize point-to-point or shared media (bus) technologies. Figure 7-14 shows a point to point arrangement for ATS(1) and shared media arrangements for ATS(2) and ATS(3).
6. If the IWS function is null, then the A20* reference point collapses into the A20 reference point. A null IWS device could be simply a physical connector without media translation such as a terminal block.

7.3.4. Home Network Security Architecture

The Network Home Security Architectures shown in Figure 7-15 and Figure 7-16 may apply to all S-flows from video content to network management, but are commonly only associated with S1 (content) flows. Figure 7-15 shows ubiquitous delivery of a single security throughout the HAN and HLN. Figure 7-16 supports the ATS as a security gateway device. Note that both architectures may coexist in a single SCS Home Network system.

7.3.5. Single Security for Both the HAN and HLN

Figure 7-15 shows a Single Security architecture in which the service provider's security (security A) terminates at the ATS devices as well as the ETS devices.

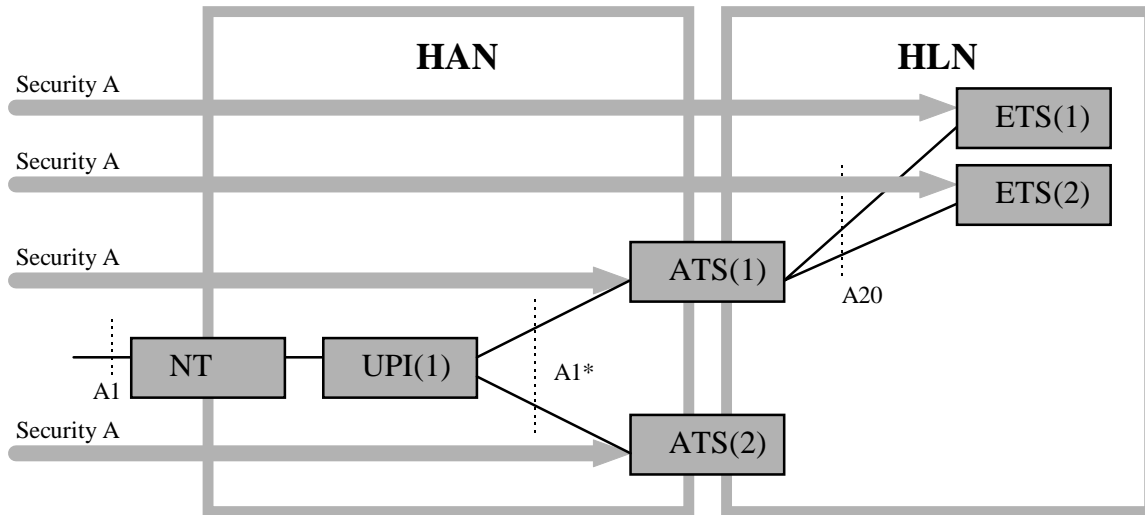

Figure 7-15: Single Security SCS Home Network Architecture

Note that if there are multiple service providers in this architecture, then an ETS device may need to support multiple security mechanisms, or all service providers must support the same security mechanism.

7.3.6. ATS Gateway Security Services

Figure 7-16: shows a different security architecture in which the service provider's security (Security A) terminates at the ATS devices. A separate security mechanism is required from ATS to ETS (Security B)

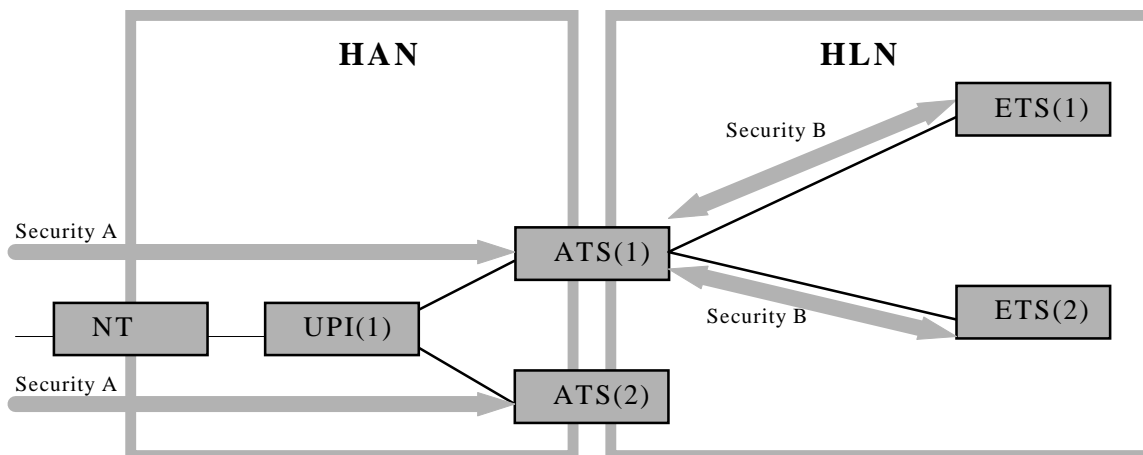

Figure 7-16: Gateway Security Architecture

The architecture shown in Figure 7-16: requires a generalised service provider independent security in ETS devices. Such security requires the owner of the S-flow, whether it be a network management, content, or any other flow, to endorse the security mechanism implemented for the HLN. This is a commonly considered arrangement where the ATS device may provide intensive conditional access services, and simpler copyright/watermarking security measures are taken once the content reaches the HLN. The architecture also supports the idea of a "firewall" to protect content from threats outside the home system.

8. Wireless networks

Besides cabled, wireless networks may be used to deliver content to End-Consumers. Wireless networks do not use wired physical media to transport information to the End-Consumers. Examples of wireless Delivery system are MMDS, LMDS, satellite and terrestrial broadcast networks. In the current DAVIC specification only MMDS/LMDS Delivery system and satellite Delivery system are specified.

For Satellite architectures a clear distinction must be made between the information flow from the End-Service Provider to the End-Consumer (downstream direction) and the return path from the End-Consumer to the End-Service Provider (upstream direction).

In the downstream direction satellite Delivery system are broadcast networks by nature: the content information can be received by anyone with an appropriate receiver (e.g., a satellite dish). To allow interactivity a separate (cabled) network must be used.

Therefore the first profile for which hertzian networks are defined is the distribution profile. This allows for broadcast and enhanced services (low interactivity).

8.1. Classification of wireless

Wireless can be classified based on the geographical span that is covered by a single distribution point of the network. In particular, satellites have a large geographical span, in the order of several thousands of kilometers. Terrestrial broadcasting networks cover a medium geographical areas in the order of a few hundreds a kilometers. MMDS serves a small regional area, in the order of some tens of kilometers. Finally, LMDS systems typically serve a very small regional area, in the order of a few kilometers.

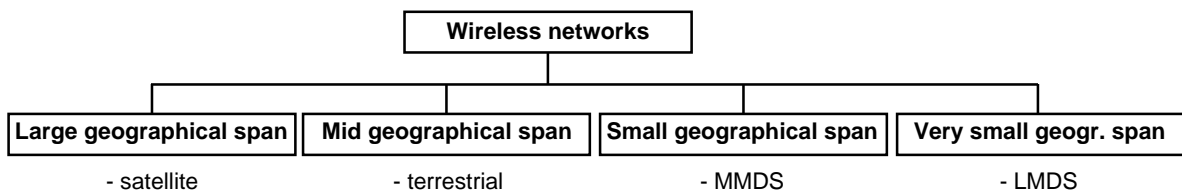

Figure 8-1 Classification of wireless networks.

8.2. MMDS

The uni-directional Multi-channel Multipoint Distribution System (MMDS) can be considered as a wireless CATV network for delivery of broadcast video programs or data information. However bi-directional MMDS can also be used to transport two-way data, video, and voice information. MMDS is primarily a line-of-sight microwave based transport technology, i.e. the transmitter and receiver more or less have to 'see' each other.

Generally the downstream information arrives via the Core Network at the Access Node. The Access Node adapts the signals and transmits the signals to an antenna. This antenna can be either co-located with the Access Node or at a different location, e.g. at the top of a hill. The antenna broadcasts the signals towards the End Users. The broadcast radius is typically in the order of 50 km. The customer premise is equipped with an MMDS antenna, an RF transceiver, and a Set Top Box (STB). The signals are adapted to match the format for the TV or STB.

Figure 8-2 shows an example of a uni-directional MMDS network.

The frequency spectrum for MMDS system is below 10 GHz, typically in the range of 2 to 3 GHz. The bandwidth for MMDS is typically in the order of 200 MHz.

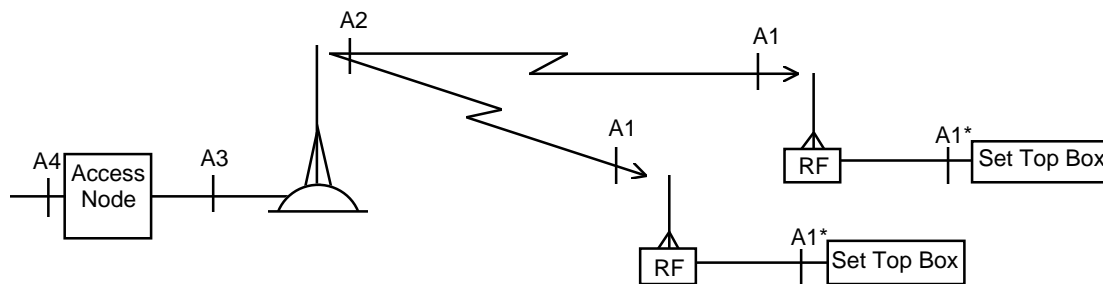

Figure 8-2 Example of a uni-directional MMDS network.

8.3. LMDS

The Local Multipoint Distribution System (LMDS) is a one-way or two way wireless system for data, video and telephony. A two-way LMDS system allows for interactive services. Just like MMDS, LMDS is a more or less line of sight microwave based transport technology. However, LMDS uses much higher RF frequencies than MMDS. LMDS systems operate at frequencies above 10 GHz. As a consequence LMDS has more bandwidth, typically in the order of 1 or 2 GHz.

Signals from the Core Network arrive at the Access Node, where the signals are adapted to the LMDS network and sent to base stations, located relatively close to the End Users. The reach of a single base station is typically in the order of 1 to 5 kilometers. Figure 8-3 shows an example of an LMDS network with several base stations.

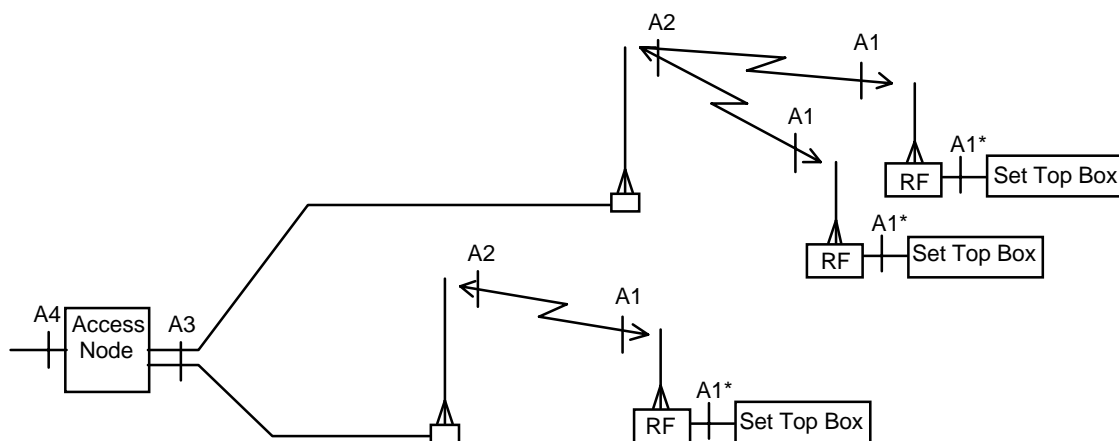

Figure 8-3 Example of a bi-directional LMDS network.

8.4. Satellite network

The main characteristic of the satellite Delivery System architecture is its distributive nature. Figure 9-4 shows the architecture for a satellite Delivery System. The content information is sent by the service provider (or rather the server) via a core network to the uplink transmitter. The Core Network may range from a single wire between server and uplink transmitter to a full switched network. In the latter case it is recommended to have an ATM Core Network to be compliant with Core Networks of cabled Delivery Systems. The uplink transmitter sends the signals to the satellite. The satellite broadcasts the signals over a wide geographic range. The content information may reach the End-Consumer in two ways. Either the End-Consumer may receive the satellite signals directly via a satellite dish see Figure 9-4, or via a CATV network. The CATV network distributes the signals to all End Consumers connected to the CATV network. In both cases the content delivery is distributive.

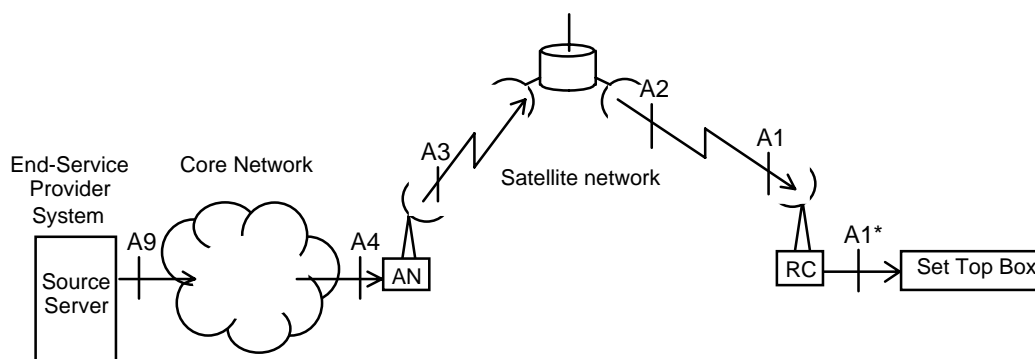

Figure 8-4 Satellite network architecture.

9. Service Architecture

The previous clauses dealt with Network Architecture aspects of Delivery Systems. This clause explains how several services can be implemented on the various specified Delivery Systems.

9.1. Enhanced and Interactive Broadcast service

The Enhanced Broadcast Service offers End Consumer broadcasted TV programs with the inclusion of information. This information may consist of web pages, advertisements, plain text or information that allows End Consumers to react on these programs. Based on this information the Set Top Box knows e.g. the destination for the End Consumers reaction to the TV program. If an End Consumer can react to a television program via an electronic return path this service is called interactive broadcast. Examples of services that can be offered via an Enhanced or interactive Broadcast Service are:

- End Consumer voting during a broadcast program
- Ordering advertised goods displayed during a broadcast program
- Selection of different broadcast program bouquets after initial access to a broadcast service provider.
- Selection of movies in near video on demand systems.

For interactive Broadcast Services a distinction can be made between the Broadcast Service Provider and the Interactive Service Provider. The Interactive Service Provider provides the Broadcast Service Provider with the information that enables interactivity with the End Consumer. The result of the interaction with the End Consumer may or may not influence the broadcast program. In the case of an interactive movie the course of the movie depends on the outcome of the End Consumer selection. In the case of a tele-advertisement to send a brochure, the End Consumers request does not influence the TV program content.

The Interactive Service Provider and the Broadcast Service Provider can either belong to the same Service Provider System or belong to (non co-located) separate Service Provider Systems. The interface between the Interactive Service Provider and the Broadcast Service Provider is currently not specified in DAVIC.

The broadcast channel is used to deliver the actual content (S1) and may be used for application control information (S2). Once the interaction channel has been established via S4, this channel is used for application control (S2). In addition the interaction channel can be used to deliver additional content information (S1) to the End Consumer.

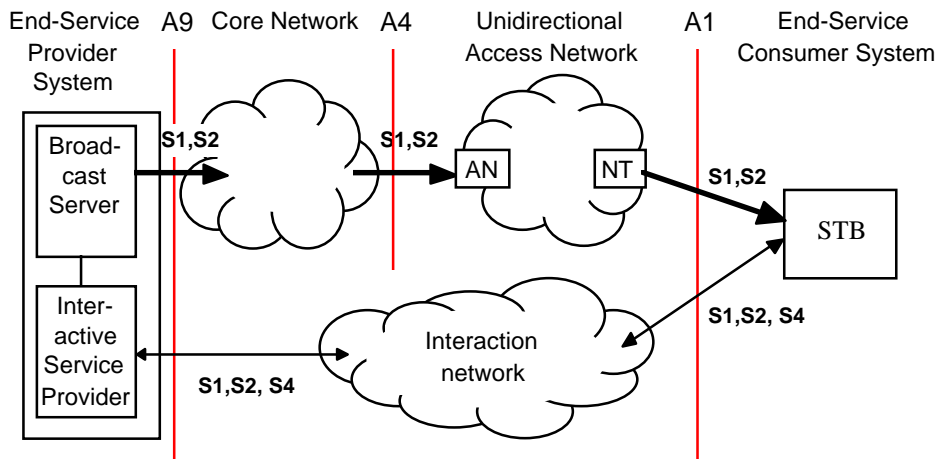

Figure 9-1 Interactive Broadcast Service architecture.

9.1.1. Downstream architecture

The Enhanced or interactive programs are distributed towards the End Consumers either via a distributive Delivery System, or via the Switched service. Examples of distributive networks that can be used are MMDS, satellite broadcast networks and CATV networks.

9.1.2. Upstream architecture

For the interactive Service an interaction channel is required to feed the reactions of the End Consumers back to the Interactive Service Provider. This interaction channel can either be implemented within the network for the downstream information, or within a separate network.

In DAVIC 1.4 only PSTN, ISDN and PLMN (public land mobile networks) have been considered to act as an interaction network for interactive services. PSTN, ISDN and PLMN interaction networks can be used e.g. in the case of satellite as well as for uni-directional CATV networks.

Since the interactive services are intended for deployment in the near future, it is expected that whichever of the PSTN, ISDN, PLMN standards already used in a region is adopted for the DAVIC interaction channel for that region. Interworking between land mobile networks and PSTN/ISDN networks has to take place within the interaction network.

9.1.3. Service Provider System architecture

The service provider architecture is further detailed in Figure 9-2. The concept of reference point A9* is introduced to allow description of the internal interfaces in a service provider system. A service provider system can consist of a number of components as shown in Figure 9-2. This can be videosevers, playout schedulers, entitlement management message inserters or other relevant components to a broadcast playout system. To allow interoperability between these subsystems in a service provider domain, DAVIC defines the A9* interface. A more detailed description of the distributed service provider system is given in part 3 of this specification.

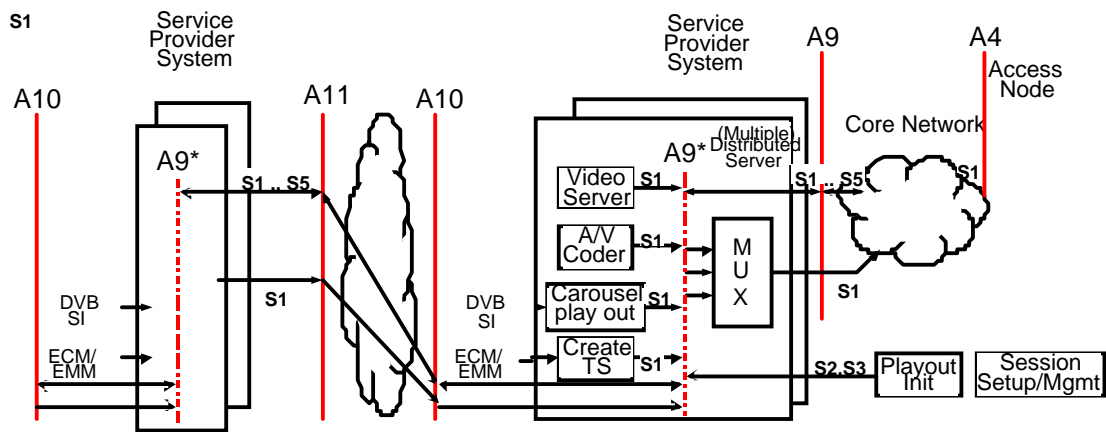

Figure 9-2 Broadcast Service Provider System architecture.

The figure also models the architectural change of two service providers communicating via the A11 and A10 interfaces. This is different from the generic DAVIC case where a content provider delivers its content through A11 and A10.

Extensions to the S1 flow are provided to support another physical interface network than ATM for non-video/audio streams. This will allow low bandwidth server hosts/service elements (e.g. ECM server, SI servers, etc.) to provide their MPEG-TS packets to a Transport Stream re-multiplexor without the need for an ATM network or separate physical point to point links.

This network is defined for use across the A9* reference point as well as on A11/A10 where there is no ATM Core network separating the paired SPS entities. This network might e.g. be an Ethernet that uses the UDP/IP stack.

S1 flow isochronicity and cross stream synchronization

DAVIC does not define any form of isochronous flow of data across the core network or any means of synchronizing one stream with another. Where streams are required to be synchronized with respect to one another, they must be transferred in a common transport stream.

However, it is accepted that any multiplexor supplied with data across the core network (i.e. from another SPS via A11/A10) will need to de-jitter input streams and the PCR before delivering the data into A9 to ensure it meets the requirements of ISO/IEC13818-9. This is also the case for the any translation between the core network and the Hertzian Access Network at the A4 reference point.

9.2. Switched Video Broadcast service

The Switched Video Broadcast Service offers End Users a large number of broadcasted TV programs over Access Networks with a relatively low capacity per End User. E.g. in the case of an ADSL Access Network, due to capacity constraints only one or two TV programs can be delivered to the End User at the same time. However, the End User may want to select these TV streams out of a much larger set of TV programs.

The Switched Video Broadcast service allows End Users to select a TV program by putting a Broadcast Control Unit (BCU) and a Replication Unit (RU) inside the network. The Broadcast Control Unit accepts commands from the Set Top Box which TV program to direct to the End User. In order to exchange these commands between BCU and STB a zapping protocol is required. Part 7 contains the zapping protocol as specified by DAVIC. The Replication Unit is the intermediate between the Broadcast Service Providers and the End Users. The Replication Unit accepts the TV streams coming from various Broadcast Service Providers and directs the requested TV programs to the End Users. The Broadcast Control Unit controls the Replication Unit. The Broadcast Control Unit and the Replication Unit can be either co-located inside the network or located at separated places.

In the first case all End User selected channels/programs that cross the A4 reference point can be transported to the STBs without need for replication. Then, the Broadcast Control Unit and the Replication Unit from which the selection is made are both located in the Core Network. (Figure 9-3).

In the second case all broadcasted channels/programs can be transported across A4. Then the Broadcast Control Unit and the Replication Unit may both be located in the Access Network (Figure 9-4).

In the third case it is assumed that not all broadcasted programs can be transported past the A4 reference point and that a selection needs to be made before that point. Furthermore it is assumed that in order to save bandwidth when more users select the same channel/program, it is better to bring one copy of the channel across A4 into the Access

Network, and replicate the channel inside the access network before A1. This means that the Broadcast Control Unit and a first Replication Unit (the entity to which all the broadcasted programs arrive and from which the programs to bring across A4 into the Access Network are selected) should be located within the Core Network (Assumption 1), while a second Replication Unit should be located in the Access Network (Assumption 2). This is shown in Figure 9-5.

Alternatively the same scenario may be realized with the architecture shown in Figure 9-6 that also distributes the Broadcast Control Unit across Core Network and Access Network.

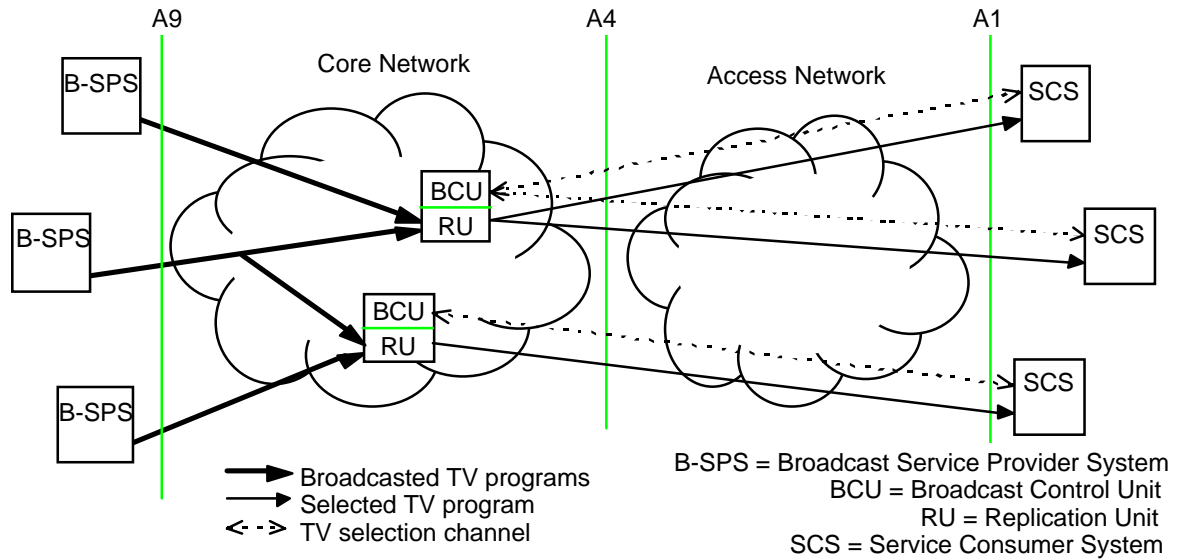

Figure 9-3 Switched Video Broadcast architecture with BCU and RU in the Core Network.

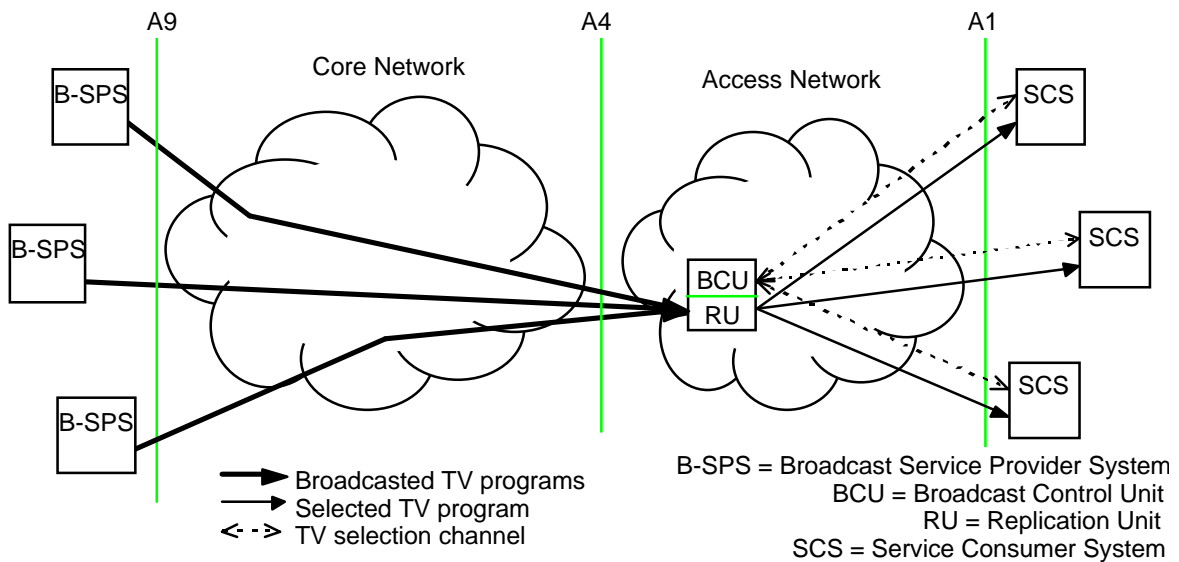

Figure 9-4 Switched Video Broadcast architecture with BCU and RU in the Access Network.

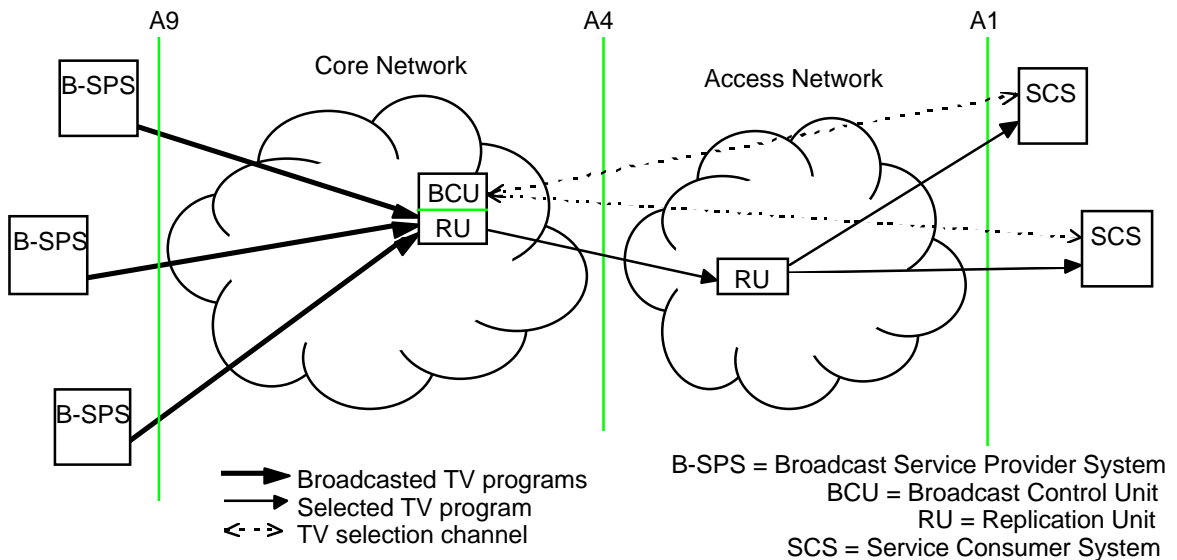

Figure 9-5 Switched Video Broadcast architecture with RU separated in the Access Network.

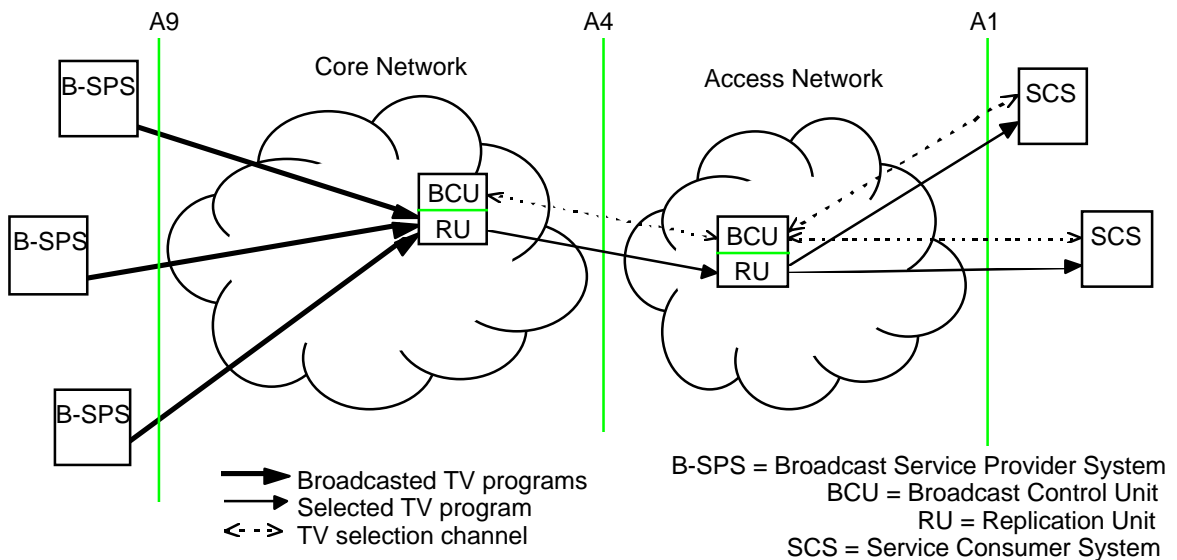

Figure 9-6 Switched Video Broadcast architecture with BCU/RU both in Access and Core Network.

As can be seen in the Figures above, the two transport streams concerned are the transport flow between the Broadcast Service Provider and the Replication Unit, and the transport stream (including the control of the transport stream) between the Replication Unit and the End User. In the scenario where the Broadcast Control Unit is located in the Core Network as well as in the Access Network (Figure 9-6), additional protocols are required to be specified between the two Broadcast Control Units across the A4 reference point.

9.2.1. Delivery of broadcast programs to the Replication Unit

The following drawing provides an illustration of the scenario for the delivery of the broadcast programs from the Broadcast Servers to the Replication Units

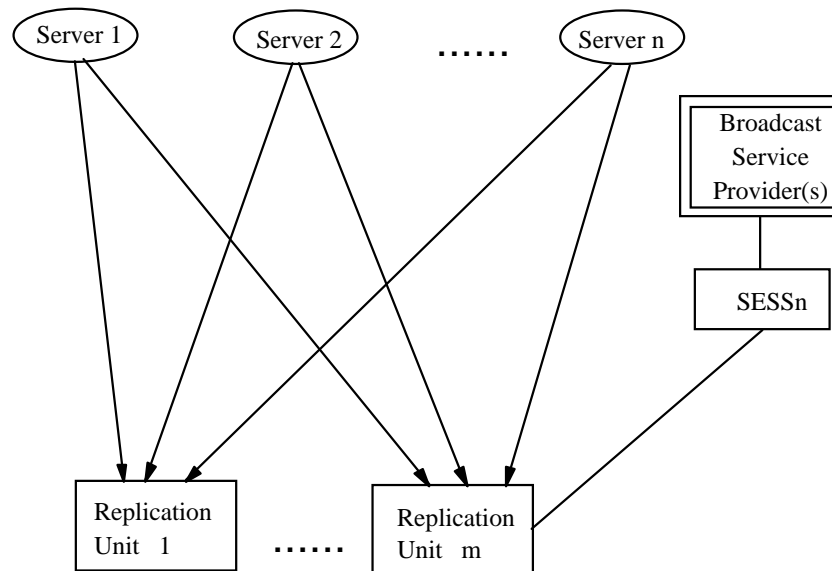

Figure 9-7 **General** scenario for the delivery of broadcast programs to the replication units.

The scenario assumes that a Broadcast Service Provider may build a service grouping programs coming from several servers.

A Broadcast Service Provider establishes program feeds for a switched broadcast service and obtains the associated Broadcast Program Ids in two ways:

- By administrative means (outside the scope of DAVIC)
- Using DSM-CC Continuous Feed sessions (for further study).

9.2.2. Program Selection Protocol

9.2.2.1. Requirements

The main requirement identified for the protocol is on latency that should be as small as possible.

9.2.2.2. Architecture and Assumption

The following figure gives a representation of the **general** architecture:

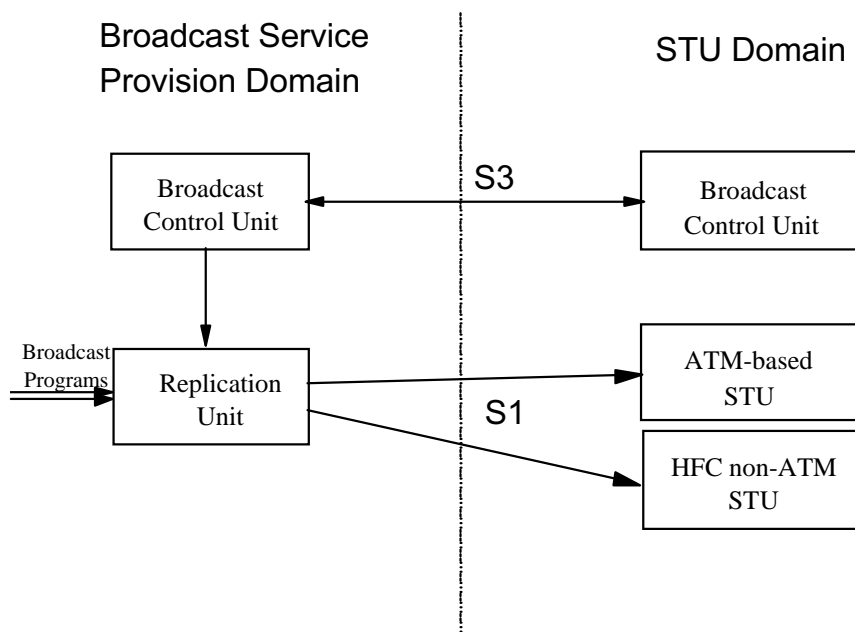

Figure 9-8 **General** architecture for the provision of switched video broadcasting.

The functional entities specific to SVB are:

- Broadcast Control Unit - This unit terminates the S3 flow that controls the selection of the broadcast channel.
- Replication Unit - This unit terminates the S1 flow on which the broadcast channels are transmitted. Content sources are provided to the Replication Unit either through satellite pick up at the unit or through ATM PVC/SVC connection to the source which can be either off satellite, a content service server with continuous broadcasting capability or a live source.

DAVIC 1.4 specifies a solution oriented to ATM-based STUs connected to a baseband access network.

1. All the broadcast programs are delivered to the Replication Unit. Within the limitation of the bandwidth available at A1, no blocking shall be guaranteed between the Replication Unit and the STU.
2. A dedicated channel is provided for the Zapping protocol on a PVC.

9.2.2.3. Transport of the program streams

Two possible solutions are defined for VPI/VCI value of the ATM channel used for the transport of the selected programs.

1. The VPI/VCI values of the ATM channel for the transport of the selected program is associated with the STU. When the user requests a program change, the BCU switches the selected program to the VC of the user. More than one ATM channel may be associated to the STU for the provision of switched video broadcasting in order to allow picture-in-picture. During program zapping the user remains “tuned” to the same ATM channel, while its content changes as a result of the program change requests.
2. The VPI/VCI values of the ATM channels for the transport of the selected programs are associated with the broadcast programs. This allows, for some implementations, that the STU may keep a mapping table of the broadcast programs to the ATM channels, so that upon selection of a program the STU may tune directly to the related ATM channel before a confirmation message is received. If the selected program is already present in the drop this would reduce latency.

The choice between solution 1 or 2 is a network option. No impact exists on the STU design. The protocol is designed to support both options as a confirmation from the network on the VPI/VCI value of the ATM channel for viewing the selected program is given.

9.3. Communicative services

Communicative services offer End Users a means of communicating with other End Users. This differs from the cases currently supported in DAVIC 1.4 where an End User communicates with a server. The plain old telephony service is a good example of a communicative service, but other services as data conferencing, multi-user games etc. are also included. Future versions of DAVIC will contain architectures and tools for communicative services.

10. Network and Service related control

10.1. Definition

Control functions are needed to allocate and release resources in the Service Provider System and Delivery System in order to provide services to End Consumers while making efficient use of the available resources. An example of a resource is an output port on the server or transport capacity in the network.

DAVIC distinguishes two levels of control associated with the Delivery System:

- Service Related Control
- Network Related Control

Service Related Control (SRC) is the highest level representing the required control functions at the level of the principal service. Network Related Control (NRC) is the lower level of control associated with the communication service supporting the principal service and is represented by the Core Network functions.

Service Related Control corresponds to the S3 flow in the DAVIC systems reference model. Network Related Control corresponds to the S4 flow in the DAVIC systems reference model.

10.2. Control functions

Service Related Control and Management and Network Related Control and Management functions interact with directories (databases) containing information on End-Consumers, End-Service Providers, service brokers, Set Top Boxes and so on. This is shown in Figure 9-1.

Functions such as user registration/cancellation perform modifications on these databases, while functions as user authentication make use of data contained therein.

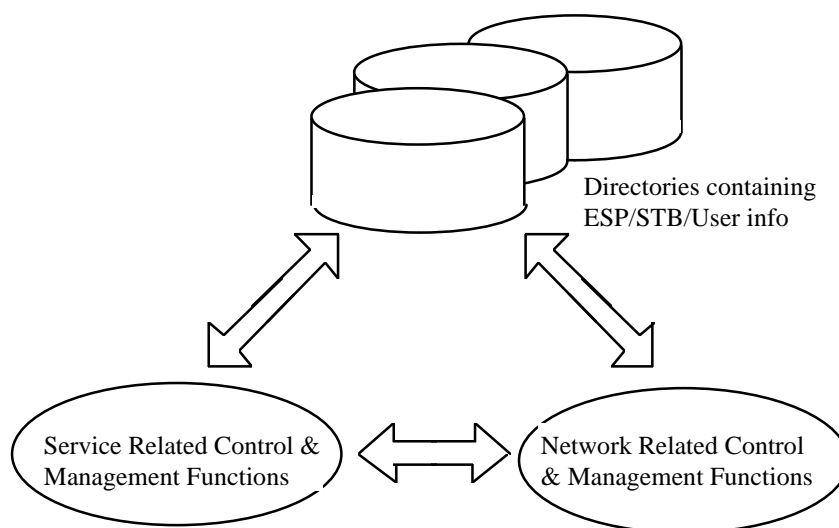

Figure 10-1 Relation between SRC&M, NRC&M and directories.

Coordination is required between Service and Network Control in order to relate the session with the underlying calls/connection (exchange of QoS parameters, network address, etc., will be part of the protocol).

10.2.1. Network functions

Network Related Control functions include connection establishment and termination, information routing and network resource allocation.

Signaling interfaces are used to control the operation of the network with respect to connection handling. It is aimed to use existing and future interfaces that are standardized by bodies such as ITU-T and ATM Forum.

Moreover the connection control signaling specification must be service independent.

The protocols for connection signaling that are terminated in the Delivery System are described in details in Part 7.

Functions which are part of the Network Related Control are:

- Call and Connection control which is the capability of the network to establish, maintain and release calls together with the related connections.

- Resource allocation which is the capability to define the elements to be used for the connection set-up according to the requests of the Session related control and to their availability.
- Routing which is the capability to find a path through the network from one end-point to another end-point where sufficient resources can be allocated.
- STB identification, which is the ability of the NRC to identify the STB (e.g., serial number) or part of the STB characteristics (STB profile, make or capabilities), to use the acceptable dialogue, protocol between the NRC and the STB.
- STB authentication that is logically subsequent to identification (a security issue), to ensure that the STB is a certified equipment, authorized to enter the DAVIC system and does not cause any damage due to its behavior. Depending on the implementation, this phase may be separated or performed together with the identification.

Network Related Control protocols may be terminated both in the Access Network and in the Core Network and in the STB or server.

For Access Network to Core Network flow, the protocol stack used depends on the architecture of the Access Network. Possible architectures are described in the following section.

10.2.2. Service functions

The following functions are part of the Service Related Control specification:

- STU download: For some applications, including perhaps basic Gateway Navigation, there is a need to download programs and data to the STU. This function controls this process and maintains any necessary service-related information.
- Navigation: This function allows the user to select Brokering Gateways, or ESPs and related DAVIC services.
- Address resolution: This function provides translation between a logical name and a network address.
- Security services: There are several functions required here, including authorization and authentication.
- Session control: This function is the processing required to set up, maintain and release sessions. It assigns session identifiers and maintains the relationships to the supporting network resources, such as calls and connections.

Service Related Control protocols are terminated both in the Delivery Systems and in the STB or Server.

10.3. Access to Core control flow

The reference point between Access Network and Core Network is named the A4 reference point. Within DAVIC it is assumed that the A4 interface is a fully digital ATM based interface. A non-ATM based A4 interface is not considered. The A4 specification is based on the following assumptions:

- a) signaling in the Access Network should be handled as transparently as possible (to limit costs)
- b) local switching has to be performed in the Core Network
- c) routing, channel concentration, user connection and OAM functions are to be performed in the Access Network
- d) billing and charging procedures do not relate with the Access Network.

The Access Network beyond the A4 reference point can be based on ATM or on MPEG Transport Stream. In the latter case a mapping function is needed in the Access Network in order to specify the relationship between ATM virtual path/channels and MPEG TSs.

In the case of a fully ATM Access Network A4 can be implemented into two ways:

1. As a pure multiplexing of ATM UNI interfaces (at VP level), for relatively simple implementations with a limited number of users per A4 port. In this case ATM VP are configured on a semi-permanent basis.
2. As an ATM interface with flexible provisioned VPC allocation and flexible VCC allocation on a per connection basis which provides concentration capabilities at the VC level.

This [general](#) architecture of the Access Network is described in more details in ETSI ETR/SPS-03040. Pure multiplexing configuration is referenced as VB5.1 interface and is specified in PREN 301-005-1. Flexible allocation is referenced as VB5.2 interface and is specified in ETS DE/SPS-03047.

For DAVIC 1.4 only the first implementation is chosen (VB5.1). However it is recognized that in future versions of the DAVIC specifications the second implementation using the VB5.2 interface will become mandatory when the VB5.2 standard has sufficiently matured.

10.3.1. Pure multiplexing of ATM UNI interfaces (VB5.1 configuration)

This method is specified for DAVIC 1.4. Pure multiplexing of ATM UNI interfaces does not allow concentration of traffic on a “per connection” basis (DAVIC 1.4) in the upstream direction. However in the downstream direction, bandwidth to the downstream flows can be assigned on a per connection basis directly by the switch to which the customer is connected, known as the Local Exchange (LE).

This means some sort of concentration in the downstream direction is possible. The bandwidth associated with each virtual path is given by the sum of bandwidth of the virtual channels contained in that virtual path. This configuration is particularly suited for services with traffic characteristics such as Video on Demand (small bandwidth in the upstream direction and large bandwidth in the downstream direction), as it allows the allocation of the downstream video channels in a flexible manner without additional burden for the Access Network. In the upstream direction fixed bandwidth virtual channels can be allocated for the transport of control information (both network control and service control).

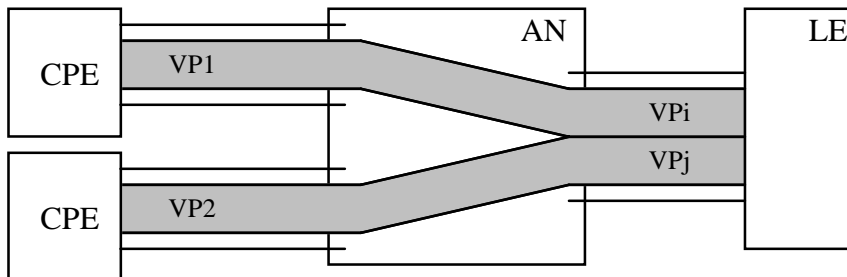

Figure 10-2 Virtual Path multiplexing (VB5.1).

10.3.2. Flexible allocation interface (VB5.2 configuration)

This method is not specified in DAVIC 1.4. It has been recognized the importance of the VB5.2 interface for concentrating and dynamically assigning VC connections over the ATM VP links. This approach is mandatory in case of large Access Networks with thousands of subscribers in order to limit the number of physical links (DAVIC 1.4). However, the current status of the VB5.2 interface is not mature enough to be taken into the DAVIC 1.4 specification and may be incorporated in later versions of the DAVIC specification.

In this configuration the customer-network signaling takes place between the STB and the ATM node via Q.2931. Then, dynamic allocation in the Access Network is obtained by the ATM node via the VB5 interface. Besides dynamic allocation VB5 also provides a concentration function. A Bearer Channel Connection (BCC) protocol (similar to that defined in V5.1 and V5.2 narrowband interfaces) is needed in order to allocate resources between the Core Network and the Access Network.

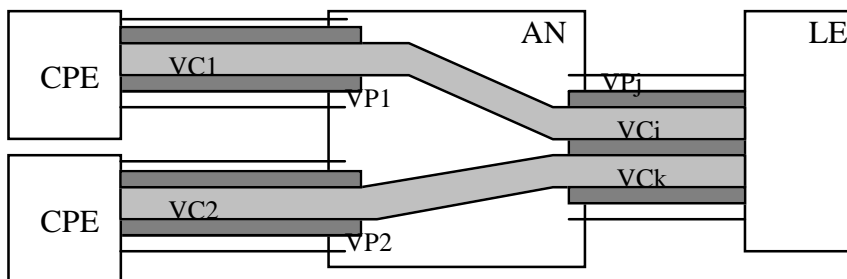

Figure 10-3 Concentration on VC basis (VB5.2).

10.3.3. ATM addressing in the Access

In case of an ATM network only addressing adaptation (VP/VC translation) has to be performed in order to allow routing and channel allocation inside the Access Network.

In the DAVIC 1.4 configuration, to identify the source of the cells in the local exchange the Virtual Path Identifier (VPI) value at the interface AN/LE are allocated in order to assign VPI uniquely to UNI (i.e., a given VPI value at the A4 interface is associated with a given A1 interface). More than one VP may be associated to a single A1 interface. The VPI values are set up by Operation and Administration procedures.

In the DAVIC 1.4 configuration, to identify the source of the cells in the local exchange the combination Virtual Path Identifier/ Virtual Channel Identifier (VPI/VCI) has to be modified in such a way that the pairs VPI/VCI are unique per physical line. The LE handles the bandwidth allocation and assigns the VPI/VCI values at the incoming and outgoing interface. The AN receives the values from the Local Exchange (LE).

10.3.4. Routing in the ATM Access

If the Access Network is completely ATM based, routing of User, Control and Management plane flows is performed on the basis of VPI/VCI field of ATM cells (assigned in a semi-permanent way or on a per call basis via the BCC protocol).

If no concentration of multiple users is done within the Access Network, the Q.2931 protocol can be used directly at the A4 interface for call and connection control, no dynamic allocation of channels across the A4 is possible.

If concentration of multiple users is done within the Access Network, there is a need to allow dynamic allocation of channels across the A4 to individual users. In this case it is required that cells be identified in the Access Network in order to be routed to individual ports. This is required not only for U-plane information, but also for signaling cells.

Identification of cells is done by dynamic mapping of VPI/VCI in the Access Network (the Access Network performs a translation of the routing field mapping of the VPI/VCI used across the A4 interface into the VPI/VCI value used across the A1 interface).

The BCC protocol must maintain a conversion table between VPI/VCI used across the A1 interface and the VPI/VCI used across the A4 interface. The BCC protocol is also responsible for assigning the VPI/VCI values across the A4 interface.

11. Network and Service management

The function of Network and Service Management is to enable a Delivery System provider or End Service Provider to offer a reliable and high-level quality service to its End Consumers. Hence, network and end service operators who will provide facilities for the delivery of multimedia services over DAVIC specified networks will need to implement network management systems. As an end-to-end Delivery System may cross the boundaries of multiple network operators, multiple Network Management Systems (NMSs) may be utilized in achieving the goal of providing a reliable service. Likewise, the End Service Providers whose content is delivered over the end-to-end network will need to implement Network Management Systems for their equipment.

The need of network management for DAVIC specified networks, leads to a requirement that DAVIC offer network management alternatives for network operators and End Service Providers. The level of network management functions that may be offered in the Network Management Systems depends upon the availability of equipment managers and agents for management of a particular type of network.

11.1. Management functions

11.1.1. Service Management functions

The following functions are parts of the Service Management specifications:

- **ESP Directory Management:** This function maintains the necessary service information about ESPs, brokers and DAVIC services (e.g., MOD). It provides means to register/deregister, modify, activate/deactivate ESP/Brokers and services and their associated parameters (profile management).
- **User Directory Management:** This function maintains the necessary information about Users (Subscribers, End-Users). It provides means to register/deregister, modify, activate/deactivate End-User and Subscriber data and its associated parameters (profile management).
- **STU Directory Management:** This function maintains the necessary information about user equipment (STUs). It provides means to register/deregister, modify, activate/deactivate End-User equipment (STUs) and its associated parameters (profile management).
- **Usage parameter collection:** There is a need to collect service related information on which charging and billing will be based. This function must cooperate with the equivalent in the Network Related Management

11.1.2. Network Management functions

The following functions are part of the Network Management specifications:

- Network client directory management: This function maintains the necessary network information about STU/ESP/other. It provides means to register/deregister, modify, activate/deactivate STU data and its associated parameters (profile management).
- Configuration Management: This function is used to configure and provision the network elements that make up an end-to-end multimedia system. It also encompasses setting up and tearing down subscriber sessions including bandwidth allocation and deallocation, and QoS verification.
- Fault and Performance Management: This function is used to proactively monitor the health of the system. This includes monitoring failures via alarms, and assisting in disaster recovery by performing root cause analysis and diagnostics.
- Security Management: This function is used to manage the security of the system that includes encryption of lower level data, and higher level authorization.
- Usage parameter collection: This function is used to collect network-related information for charging and billing purposes. In addition, the function includes network resource usage accounting to plan for future network expansion. This function should co-operate with the equivalent in Service related management for billing and charging purposes.

11.2. Management architecture

Conceptually, an End Consumer may utilize several Core Networks owned by different Network Providers to reach one of many servers to receive service. These multiple Core Networks and servers will be managed by separate NMSs to provide reliable service. The business boundaries that exist between enterprises (different providers) in an end-to-end multimedia system provide a foundation for definition of the network management architecture. As the end-to-end multimedia system can be partitioned in several management domains based on provider boundaries, only a few sample scenarios of the management architecture are defined in this section.

The defined network management architecture in turn defines the protocol stacks to be used for different management interfaces involved. These protocol stacks are found in Part 7 of the DAVIC 1.4 Specification.

11.2.1. Scenario 1

Figure 11-1 shows a scenario in which the end-to-end multimedia system is partitioned into two management domains based on provider boundaries. One management domain contains the Service Provider that owns the server. The second management domain contains the Delivery System provider that owns the Core Network, Access Network and the STB as well. These two management domains are managed by separate Network Management Systems to provide reliability in their portion of the end-to-end system. There is peer to peer communication between the two NMSs. Only the S5 management information flows are identified in the figure.

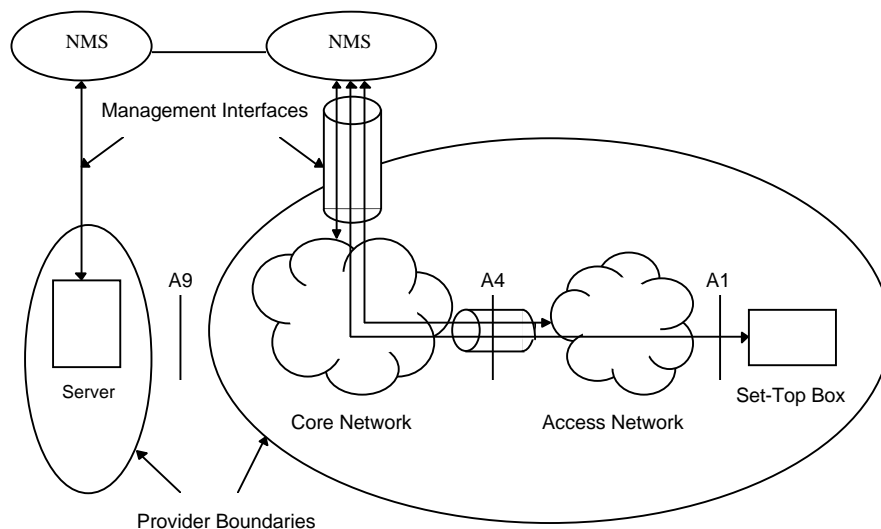

Figure 11-1 Scenario 1.

The Figure 11-2 shows a scenario in which the end-to-end multimedia system is partitioned into two management domains based on provider boundaries. One management domain contains the Service Provider that owns the

server and the STB. The second management domain contains the network provider which owns the Core Network, and the Access Network. The two domains are managed by separate Network Management Systems. There is peer to peer communication between the two NMSs. Only the S5 management information flows are identified in the figure.

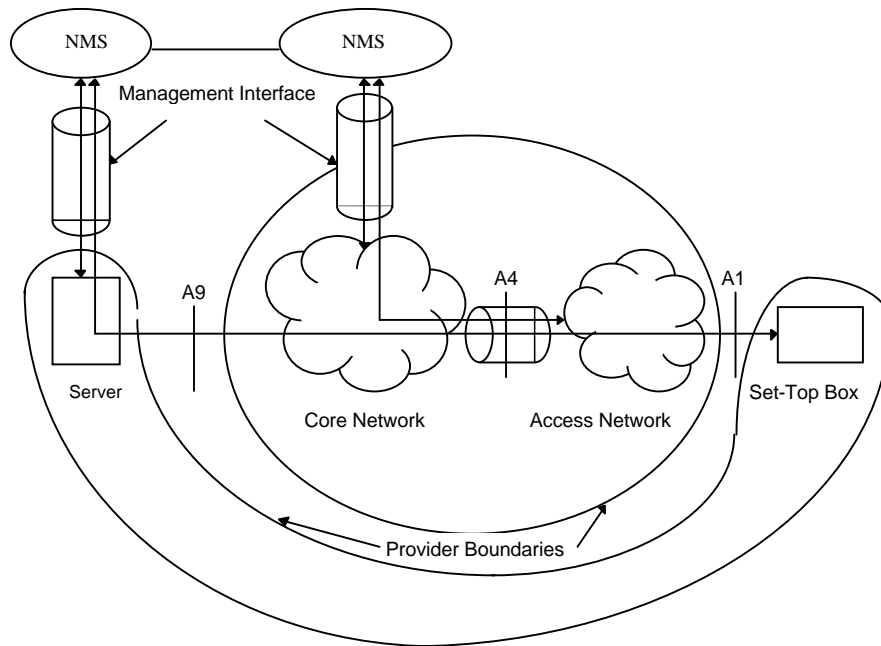

Figure 11-2 Scenario 2.

The Figure 11-3 shows a scenario in which the End Consumer owns the STB. The end-to-end multimedia system without the STB can now be partitioned into management domains based on the ownership of the several components of the system. The figure identifies one of the possible scenarios.

The two NMSs used to manage the management domains have peer to peer communication. Only the S5 management information flows are identified.

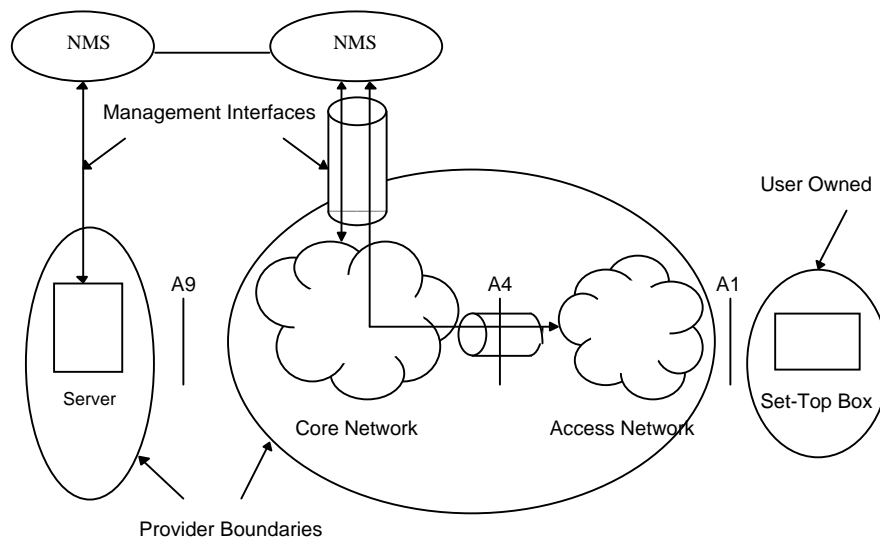

Figure 11-3 Scenario 3.

11.2.2. Scenario 4

The Figure 11-4 shows a single enterprise scenario in which one provider owns the entire network. In this case, conceptually only one NMS is required to manage the network to provide reliable service. However to decrease complexity, the network can be partitioned into subnetworks to provide distributed management. Only the S5 management information flows are identified in the Figure 11-4.

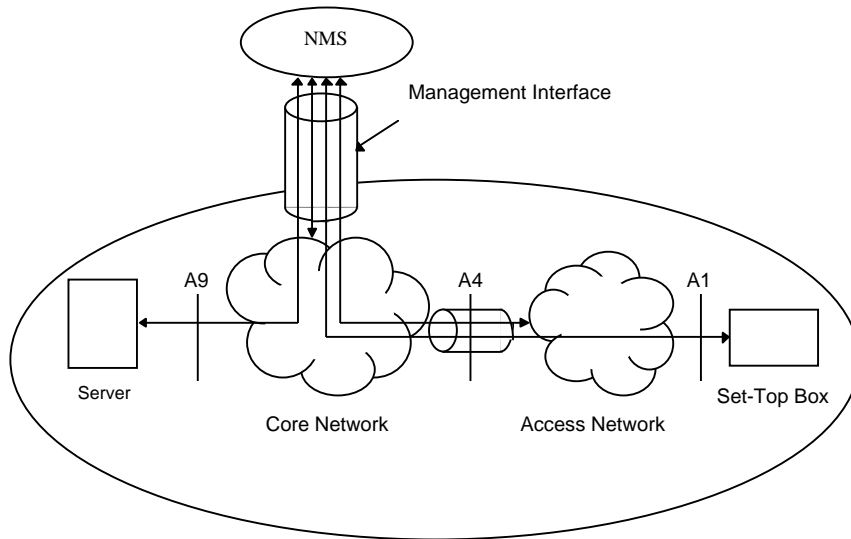

Figure 11-4 Scenario 4.

The Figure 11-5 shows a scenario in which the access network provider also owns the STB. The end-to-end multimedia system can now be partitioned into management domains based on the ownership of the several components of the system as below.

The three NMSs used to manage the management domains have peer to peer communication. Only the S5 management information flows are identified.

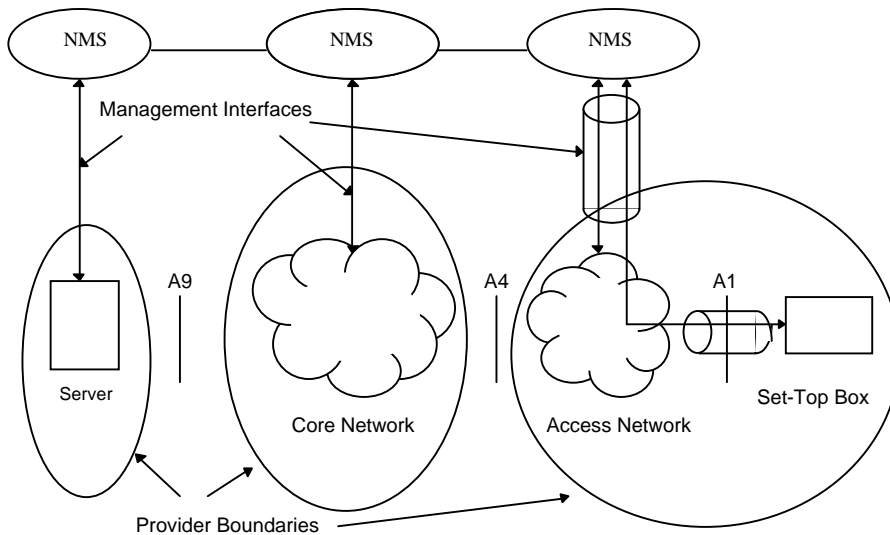

Figure 11-5 Scenario 5.

11.3. Telecommunication Management Network Reference Model

In order to outline a baseline for determining short term and long term network management function options, the TMN reference model is given here. It is expected that network management system solutions in the short term

will support a minimal number of functions, selected primarily from the lower layers. Evolution to long term solutions is expected to involve functions being added incrementally.

Table 10-1 TMN reference model

	performance	fault	configuration	accounting	security
Business Management Layer					
Service Management Layer					
Network Management Layer					
Element Management Layer					
Element Layer					

11.4. Network Management Protocols

There are currently two basic candidates for network management protocols to be used: CMIP defined by ITU-T X.711 and SNMP defined by RFC 1157. SNMPv2 is also a candidate protocol but in this discussion is referred to by "SNMP". In [general](#), it is said that CMIP is more suited for public networks (core and access networks), while SNMP is more appropriate for server and STU equipment. The DAVIC architecture uses several different types of access networks. The choice of a standard network management protocol for these networks is difficult since: a) most of these access networks have no standard network management protocol associated with them, and b) most of these networks, for example, HFC access network, contain simple network elements such as amplifiers and power supplies for which a standards based approach is seen as too demanding. For the access networks, for the simple network elements in which a standards based approach would mean a large overhead, a proxy-based management approach is recommended, whereas for large and complex elements which can support a standards based approach CMIP or SNMP is recommended. The choice of network management protocols to be used, however, is left to the service or network provider.

11.5. Reference Standards and Requirements

Several standards bodies and fora are currently defining network management system requirements.

For the core ATM networks, the ATM Forum has completed the M4 Network Element specification that deals with ATM core network elements, that is, the ATM switches. The ATM Forum is currently working on M4 Network View specification that deals with end-to-end ATM networks.

DAVIC supports many different type of access networks. Currently, some of the access networks specified do not have standard bodies defining manager-agent relationships. For those type of technologies, additional work is needed to fully define the DAVIC network management framework.

DAVIC has specified a STU MIB for Set Top Units.

The management protocol to be used by the server is SNMP.

Management information models should be defined so that all network elements are accessible for the management of DAVIC services.