



DAVIC 1.4.1 Specification Part 5

Service Consumer System Architecture

(Technical Report)

NOTICE

Use of the technologies described in this specification may infringe patents, copyrights or intellectual property rights of DAVIC Members or non-members.

Neither DAVIC nor any of its Members accept any responsibility whatsoever for damages or liability, direct or consequential, which may result from use of this specification.

© Digital Audio-Visual Council 1998.

Published by Digital Audio-Visual Council

Geneva, Switzerland

CONTENTS

FOREWORD	IV
INTRODUCTION	V
1. SCOPE	1
2. REFERENCES	2
2.1 Normative References	2
2.2 Informative References	2
3. DEFINITIONS	3
4. ACRONYMS AND ABBREVIATIONS	4
5. CONVENTIONS	5
6. SERVICE CONSUMER SYSTEM ARCHITECTURE	6
7. STU REFERENCE POINTS	9

Foreword

The Digital Audio-Visual Council (DAVIC) is a non-profit Association registered in Geneva in 1994. The objective of DAVIC is to promote the success of interactive digital audio-visual applications and services through specification of open interfaces and protocols.

The DAVIC 1.4 Specification was developed by representatives of DAVIC member organizations. It is a public document based on submissions from members and non-members in response to the public Calls For Proposals which were issued in October 1994, March 1995, September 1995, December 1995, March 1996 and September 1996. The specification has full backward compatibility with the earlier versions [DAVIC 1.0](#), [DAVIC 1.1](#) and [DAVIC 1.2](#). [DAVIC 1.3](#) has been available on the Internet since June 1997. [DAVIC 1.3.1](#) is a point release issued in Milan, March 1998.

DAVIC 1.4 is a single specification consisting of 14 parts.

- [Part 1: Description of Digital Audio-Visual Functionalities](#)
- [Part 2: System Reference Models and Scenarios](#)
- [Part 3: Service Provider System Architecture](#)
- [Part 4: Delivery System Architecture and Interfaces](#)
- [Part 5: Service Consumer System Architecture](#)
- [Part 6: Management Architecture and Protocols](#)
- [Part 7: High And Mid-Layer Protocols](#)
- [Part 8: Lower-Layer Protocols and Physical Interfaces](#)
- [Part 9: Information Representation](#)
- [Part 10: Basic Security Tools](#)
- [Part 11: Usage Information Protocols](#)
- [Part 12: System Dynamics, Scenarios and Protocol Requirements](#)
- [Part 13: Conformance and Interoperability](#)
- [Part 14: Contours: Technology Domain](#)

The DAVIC PAS (Publicly Available Specification) forwarded to ISO/IEC JTC 1 for transposition into an international standard is a subset of the DAVIC 1.4 specification consisting of the normative parts (2, 6-12 and 14). In addition, the essential informative Part 1 which provides categorised sets of user and market requirements and has two informative annexes which are closely integrated with the normative technology conformance details provided in Part 14 is proposed as an ISO/IEC JTC 1 Technical Report.

All versions and corrigenda of DAVIC specifications are available from the DAVIC web site.

Contact Information

DAVIC Secretariat
c/o Societa' Italiana Avionica Spa
Strada Antica di Collegno, 253
I-10146 Torino - Italy
Tel.: +39 11 7720 114
Fax: +39 11 725 679
Email: secretariat@davic.org
DAVIC Home Page: <http://www.davic.org>

Introduction

DAVIC specifications define the minimum tools and dynamic behavior required by digital audio-visual systems for end-to-end interoperability across countries, applications and services. To achieve this interoperability, DAVIC specifications define the technologies and information flows to be used within and between the major components of generic digital audio-visual systems. Interoperability between these components and between individual sub-systems is assured through specification of tools and specification of dynamic systems behavior at defined reference points. A reference point can comprise one or more logical (non-physical) information-transfer interfaces, and one or more physical signal-transfer interfaces. A logical interface is defined by a set of information flows and associated protocol stacks. A physical interface is an external interface and is fully defined by its physical and electrical characteristics. Accessible reference points are used to determine and demonstrate compliance of a digital audio-visual subsystem with a DAVIC specification.

DAVIC 1.3.1 parts can be classified into four major groups. A summary of each part under each of the four headings follows.

Requirements and Framework (Parts 1-2)

Part 1 provides a detailed listing of the functionalities required by users and providers of digital audio-visual applications and systems. It introduces the concept of a contour and defines the IDB (Interactive Digital Broadcast) and EDB (Enhanced Digital Broadcast) functionality requirements which are used to define the normative contour technology toolsets provided in Part 14.

Part 2 defines the normative DAVIC technical framework. It provides a vocabulary and a Systems Reference Model, which identifies specific functional blocks and information flows, interfaces and reference points.

Architectural Guides (Parts 3-5)

Parts 3 and 4 and 5 are technical reports which provide additional architectural and other information for the server, the delivery-system, and the service consumer systems respectively.

Part 3 defines how to load an application, once created, onto a server and gives information and guidance on the protocols transmitted from the set-top user to the server, and those used to control the set-up and execution of a selected application.

Part 4 provides an overview of delivery systems and describes instances of specific DAVIC networked service architectures. These include physical and wireless networks. Non-networked delivery (e.g. local storage physical media like discs, tapes and CD-ROMs) are not specified.

Part 5 provides a service consumer systems architecture and a description of the DAVIC Set Top reference points defined elsewhere in the normative parts of the specification.

Technology Toolsets (Parts 6-11)

The next six parts are normative. They specify and comprise the technology toolsets and relevant protocols across the entire audio-visual creation and delivery chain.

Part 6 specifies the information model used for managing the DAVIC systems. In particular, this part defines the managed object classes and their associated characteristics for managing the access network and service-related data in the delivery system. Where these definitions are taken from existing standards, full reference to the required standards is provided. Otherwise a full description is integrated in the text of this part. Usage-related information model is defined in Part 11.

Part 7 defines the technologies used for high and mid-layer protocols for DAVIC systems. In particular, this part defines the specific protocol stacks and requirements on protocols at specific interfaces for the DAVIC content, control and management information flows.

Part 8 defines the toolbox of technologies used for lower layer protocols and physical interfaces. The tools specified are those required to digitize signals and information in the Core Network and in the Access Network. Each tool is applicable at one or more of the reference points specified within the delivery system. In addition a detailed specification is provided of the physical interfaces between the Network Interface Unit and the Set Top Unit and of the physical interfaces used to connect Set Top Boxes to various peripheral devices (digital video recorder, PC, printer). The physical delivery system mechanisms included are copper pairs, coaxial cable, fiber, HFC, MMDS, LMDS, satellite and terrestrial broadcasting.

Part 9 defines what the user will eventually see and hear and with what quality. It specifies the way in which monomedia and multimedia information types are coded and exchanged. This includes the definition of a virtual machine and a set of APIs to support interoperable exchange of program code. Interoperability of applications is achieved, without specifying the internal design of a set top unit, by a normative Reference Decoder Model which defines specific memory and behavior constraints for content decoding. Separate profiles are defined for different sets of multimedia components.

Part 10 defines the interfaces and the security tools required for a DAVIC 1.3.1 system implementing security profiles. These tools include security protocols which operate across one or both of the defined conditional access interfaces CA0 and CA1. The interface CA0 is to all security and conditional access functions, including the high speed descrambling functions. The interface CA1 is to a tamper resistant device used for low speed cryptographic processing. This cryptographic processing function is implemented in a smart card.

Part 11 specifies the interface requirements and defines the formats for the collection of usage data used for billing, and other business-related operations such as customer profile maintenance. It also specifies the protocols for the transfer of Usage Information into and out of the DAVIC System. In summary, flows of audio, video and audio-visual works are monitored at defined usage data collection elements (e.g. servers, elements of the delivery system, set-top boxes). Information concerning these flows is then collected, processed and passed to external systems such as billing or a rights administration society via a standardised usage data transfer interface.

Systems Integration, Implementation and Conformance (Parts 12-14)

Part 12 is a normative part which defines system dynamic behavior and physical scenarios. It details the locations of the control functional entities along with the normative protocols needed to support the systems behavior. It is structured as a set of protocol walk-throughs, or "*Application Notes*", that rehearse both the steady state and dynamic operation of the system at relevant reference points using specified protocols. Detailed dynamics are given for the following scenarios: video on demand, switched video broadcast, interactive broadcast, and internet access.

Part 13 is an informative report which provides guidelines on how to validate the systems, technology tools and protocols through conformance and / or interoperability testing.

Part 14 provides the normative definition of DAVIC Technology Contours. These are strict sets of Applications, Functionalities and Technologies which allow compliance and conformance criteria to be easily specified and assessed. DAVIC 1.3.1 contains the full details of two contours. These are the Enhanced Digital Broadcast (EDB) and Interactive Digital Broadcast (IDB). Part 14 specifies required technologies and is a mandatory compliance document for contour implementations.

Service Consumer System Architecture

1. Scope

Part 5 of this Specification provides a service consumer systems architecture and a description of the DAVIC Set Top reference points defined elsewhere in the normative parts of the specification.

2. References

The following documents contain provisions which, through reference in this text, constitute provisions of this Specification. At the time of publication, the editions indicated were valid. All referenced documents are subject to revision, and parties to agreements based on this Specification are encouraged to investigate the possibility of applying the most recent editions of the standards indicated below. Members of IEC and ISO maintain registers of currently valid International Standards. The Telecommunication Standardization Bureau (TSB) maintains a list of currently valid ITU-T Recommendations.

2.1 Normative References

There are no Normative References for Part 5.

2.2 Informative References

There are no Informative References for Part 5.

3. Definitions

In Part 5 no new terms are defined.

Part 2 Annex A defines numerous terms and, in some cases, alternative interpretations that are appropriate in other contexts. The definitions in the annex were derived from various sources: some are direct quotes, others have been modified.

Supplementary definitions in Part 2 Annex A are not normative and are provided for reference purposes only.

4. Acronyms and abbreviations

Part 2 Annex B contains a complete set of acronyms and abbreviations used throughout the DAVIC 1.3.1 Specification. The following acronyms and abbreviations are used in this Specification:

API	Application Program Interface
DSM-CC U-U	Digital Storage Media - Control Commands User-User
DSM-CC U-N	Digital Storage Media - Control Commands User-Network
ECM	Entitlement Control Message
HMSC	Human or Machine Service Consumer
MHEG-5	Multimedia and Hypermedia information coding Expert Group - Part 5. Support for base-level interactive applications
NIU	Network Interface Unit
RTE	RunTime Engine
SCS	Service Consumer System
TS	Transport Stream
TV	Television
VCR	Video Cassette Recorder

5. Conventions

The style of this Specification follows the “Guide for ITU-T and ISO/IEC JTC 1 cooperation, Appendix II: Rules for presentation of ITU-T | ISO/IEC common text (March, 1993)”.

6. Service Consumer System Architecture

The following diagram of the Service Consumer System (SCS) reference model shows modules that are commonly found in an SCS. This section is informative for the purpose of showing one possible implementation of the DAVIC reference model. This section in no way defines how an SCS must be implemented to support DAVIC specifications. The described modules in the diagram can be divided and combined in any way that an implementor desires. The only requirements for the SCS is that the normative reference points meet the defined specification outlined in Section 7.

In this example the NIU, Set Top Unit and Human or Machine Service Consumer are different physical devices and the Human or Machine Service Consumer is a display (e.g. TV). This is just one example. The Human or Machine Service Consumer could just as easily have been a storage device (e.g. VCR, Digital Video Recorder) or the STU and NIU could be one physical unit.

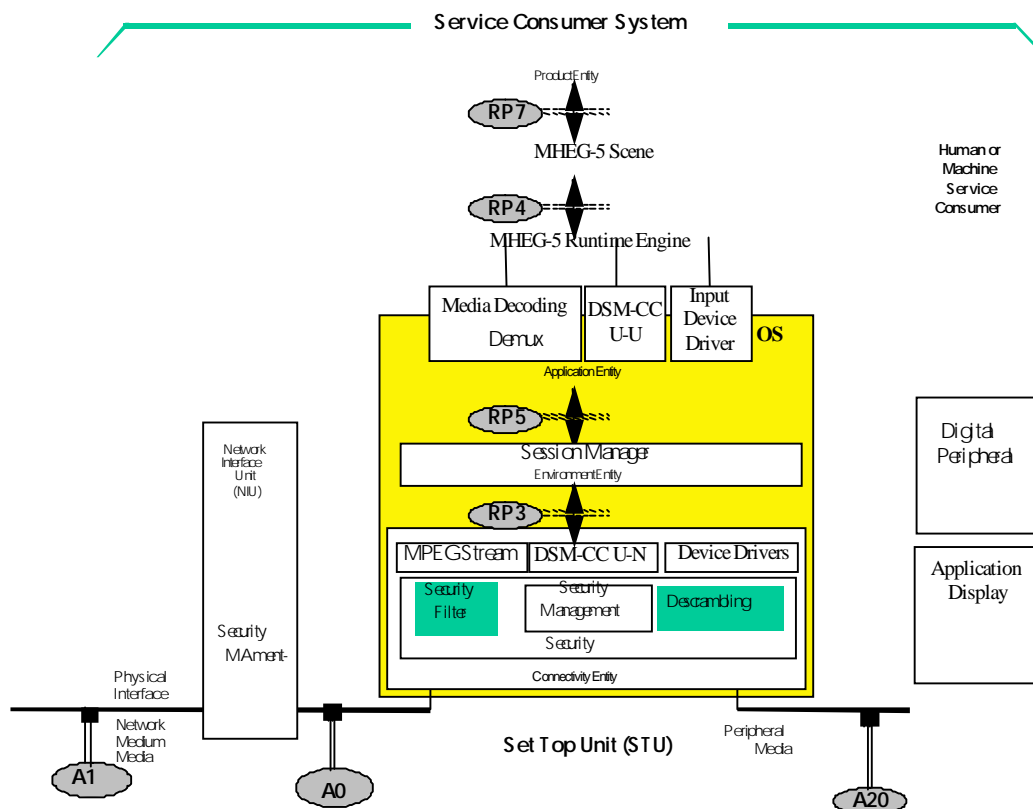

Figure 1. Example SCS Reference Model (with modules common in commercial SCSs)

Table 6-1. Module explanation for Figure 1. Example SCS Reference Model

COMPONENT	DESCRIPTION
NIU	The network dependent interface between a DAVIC network and a DAVIC STU.
STU	The main unit responsible for receiving, interpreting and correctly formatting information to be displayed, as in the example, on the HMSC.
<i>Connectivity Entity</i>	The entity that deals with the low level connectivity between STU and the server as well as the communication between the STU and HMSC. The sub components are listed below.
DSM-CC U-N	The User to Network communication module defined in DSM-CC.
MPEG Stream	The stream (video and audio) transport mechanism.
Device Driver	The driver responsible for sending the display information to the HMSC.
Security	This module represents the security functions for the service consumer system. It is divided into 3 parts: security management, security filter and descrambling. These components are explained below.
Security Management	This module manages secure session negotiation, scrambling algorithm negotiation (or identification in a 1-way broadcast environment), authentication (1-way and 2-way), and secure transactions (e.g. payment). This module is represented as possibly being in two places (NIU or STU).
Security Filter	This module extracts ECM messages and forwards them to the Security Management module.
Descrambling	This module unscrambles protected data upon receiving appropriate descrambling keys from the Security Management.
<i>Environment Entity</i>	The entity that deals with session setup for the STU.
Session manager	This module sets up and manages the session.

<i>Application Entity</i>	The entity that deals with the running of an application and all the underlying components needed for the application. The sub components are listed below.
Media Decoding	This module decodes and manipulates all the media (e.g. MPEG, Bitmap, Text, Audio, etc.) that is transferred to the system This is where the Demux of MPEG2-TS stream is also done.
DSM-CC U-U	This module translates the RTE requests to DSM-CC User to User messages.
Input Device Driver	The module that handles the events from the user input device.
MHEG-5 Runtime Engine	The module that interprets the MHEG-5 data to run an application.
MHEG-5 Scene	Structure that co-ordinates the presentation (visual and audible) of MHEG-5 objects. Any MHEG-5 application is made up of scenes and objects. A scene contains a group of objects used to present information (graphics, sound, video, etc.) along with localised behaviour based on events (e.g. the Left button being pushed activates a sound). At most one scene is active at any one time.
OS	The operating system of the STU.
Human or Machine Service Consumer Device	In the above example this is a TV set.
Application Display	A software/hardware component that displays and plays the presentable parts of an application.
Digital Peripheral Device	A peripheral device, such as a digital VCR or Personal Computer, that may use the STU Dataport for MPEG-TS or IP based applications.
<i>Product Entity</i>	An entity, such as a Set Top Box, that embodies an implementation of DAVIC compliant functions

7. STU Reference Points

The normative requirements of the Service Consumer System are defined at the reference points. The interfaces defined at the reference points can be implemented in software and need not always be physically present in the SCS. These interfaces can be achieved by downloading the appropriate software components partially or wholly prior to when they are needed. DAVIC compliance can only be achieved if DAVIC 1.3.1 applications can successfully execute once all the interface components are present in the system.

The SCS reference points that have been defined for DAVIC 1.3.1 are A0, A1, A20 and RP4. The reference points RP3, RP5 and RP7 have not been defined for DAVIC 1.3.1. The informative table below shows the reference points and the corresponding location of the normative definition for that point.

Table 7-1. Service Consumer System Normative Table

Reference Point	Location of Normative Definition
A0 (implemented if NIU and STU are physically distinct)	Part 7, Section 12 - A0 Initialisation Part 8, Section 8 - NIU to STU Interface
A1	Part 12, Section 12.2 lists the A1s and refers to the detailed specification in Part 8
A20 Video Interface	Part 9, Section 6.10
A20 Audio	Part 9, Sections 6.7, 6.8, 6.9. Additional information provided in Annex M, IEC 60958 and IEC 61937.
A20 Dataport (in addition to the Audio and Video analog outputs)	Part 8, Section 9 - STU Dataport Interface Part 12
RP4-Application Interface	Part 9, Section 9: Application Format
RP4-Data Types	Part 9, Section 9.2.4: Data type supported, mapped to MHEG-5 object content data
RP3	Not Defined in DAVIC 1.3.1
RP5	Not Defined in DAVIC 1.3.1
RP7	Not Defined in DAVIC 1.3.1